

A close-up photograph of a wild pig's face, showing its dark, coarse fur and intense, reddish-brown eyes. The pig's snout and tusks are visible at the bottom of the frame. A green rectangular text box is overlaid on the right side of the image.

A LANDOWNER'S GUIDE FOR

WILD PIG MANAGEMENT

PRACTICAL METHODS FOR WILD PIG CONTROL

Bill Hamrick, Mark Smith, Chris Jaworowski, & Bronson Strickland

Mississippi State University Extension Service &
Alabama Cooperative Extension System

ACKNOWLEDGMENTS

We thank USDA/National Institute of Food and Agriculture, the Renewable Resources Extension Act (RREA), the Alabama Wildlife Federation, Mississippi State University, Auburn University, Alabama Department of Conservation and Natural Resources, and Mississippi Department of Wildlife, Fisheries, and Parks for their financial and moral support of this publication. The authors also acknowledge with gratitude the contributions of Scott Alls, Carl Betsill, Jay Cumbee, Kris Godwin, Parker Hall, and Dana Johnson, USDA/APHIS-Wildlife Services; Billy Higginbotham, Texas AgriLife Extension Service; Sherman "Skip" Jack, Mississippi State University College of Veterinary Medicine; Joe Corn, Southeastern Cooperative Wildlife Disease Study; Ricky Flynt and Brad Young, Mississippi Department of Wildlife, Fisheries, & Parks; Ben West, University of Tennessee Extension Service; and Jack Mayer, Savannah River National Laboratory.

The mention of commercial products in this publication is for the reader's convenience and is not intended as an endorsement of those products nor discrimination against similar products not mentioned.

To obtain additional copies of this publication, please visit <http://www.wildpiginfo.com/resources/>, <http://msucares.com/pubs>, or <http://www.aces.edu/pubs>, where an electronic copy can be downloaded at no charge.

Printed copies may also be ordered through Mississippi State University Extension Service and Alabama Cooperative Extension System.

- Mississippi State University Extension Service: Contact your county Extension office.
- Alabama Cooperative Extension System: Call (334) 844-1592 or e-mail publications@aces.edu

Published by

Mississippi State University Extension Service and

Alabama Cooperative Extension System, Alabama A&M University and Auburn University

Several cover photos provided by Chris Jaworowski, Dee Mincey, Randy DeYoung, Ronald Britnell, & Bill Hamrick.

CONTENTS

Introduction	1
Range Expansion	2
Damage	6
Agricultural Damage.....	7
Forest Damage.....	7
Threats to Native Wildlife	8
Environmental Damage	8
Learn to Recognize the Signs	9
Wild Pigs and Disease	12
Disease Prevention	12
Management	14
Trapping Wild Pigs.....	14
Scouting the Trap Location	15
Conditioning Pigs to the Trap.....	16
Baiting and Setting the Trap	18
Types of Pig Traps	18
Box Traps	18
Cage Traps	19
Corral Traps.....	20
What Is the Appropriate Size for a Corral Trap?	20
Building a Circular Corral Trap	20
Trap Door Designs.....	22
Single-Catch Trap Doors	22
Multicatch Trap Doors	22
Trigger Mechanisms	25
The Root Stick.....	25
The Trip Wire.....	26
High-Tech Pig Trapping	27
Five Steps for Systematic Wild Pig Removal.....	29
Snaring Wild Pigs	30
Euthanizing Wild Pigs.....	30

Shooting and Hunting Wild Pigs.....	30
Nontarget Species.....	32
Is “All-Out War” on Wild Pigs a Good Idea?	34
Where Do We Go From Here?	35
Appendix I: Zoonotic Diseases	36
Appendix II: The Corral Trap	37
Appendix III: Trap Door Designs	38
Appendix IV: Trigger Mechanisms	43
Appendix V: Monitoring Pig Traps and Strategic Baiting	48
Glossary	51
Additional Resources	53
Authors	54
Guest Articles	
Disease Impacts of Wild Pigs.....	13
Using Remote-Sensing Cameras to Enhance Wild Pig Trapping Efficiency.....	17
Decoying Wild Pigs.....	24
Trip Wires Versus Root Sticks.....	26
Nighttime Options for Wild Pig Control	31
Hunting Pigs with Dogs.....	33

INTRODUCTION

Wild pigs are not native to the Americas. They were first introduced to the United States in the 1500s by the Spanish explorer Hernando DeSoto, who traveled extensively throughout the Southeast.

Because pigs are highly adaptable and capable of fending for themselves, they were a popular livestock species for early explorers and settlers. In the centuries following European exploration and colonization of the eastern United States, settlers, farmers, and some Native Americans continued to promote the spread of pigs by using free-range

Wild pigs are not native to the Americas.



livestock management practices. In the early 1900s, Eurasian or Russian wild boar were introduced into portions of the United States for hunting purposes. As a result of cross-breeding with wild domestic stock, many hybrid populations now exist throughout the wild pig's range.



Alabama DCNR, Wildlife and Freshwater Fisheries Division, Chris Jaworowski



Wild pig is a collective term used to refer to feral domestic pigs (left), Eurasian wild boar (right), and hybrids resulting from interbreeding of the two. As a result of interbreeding and their diverse background, wild pigs come in a variety of colors and sizes.

RANGE EXPANSION

Today, wild pigs are both numerous and widespread throughout much of the United States, with established populations in at least 36 states and an additional 12 states reporting a presence of wild pigs. Historically, problems with wild pigs were limited mostly to the southeastern states, California, Hawaii, and Texas. However, in the last 20 years, wild pig ranges have expanded dramatically to include much of the United States, and populations now exist in such northerly climates as Michigan, North Dakota, and the provinces of Manitoba and Saskatchewan in Canada. This current distribution of wild pigs, almost nationwide in scope, is not a consequence of natural events. Instead, it has resulted largely from translocation of wild pigs by humans and from “the nature of the beast.”

THE HUMAN FACTOR

The popularity of wild pigs as a game species has played a major role in the expansion of their range throughout the United States. In some cases, the sudden presence of wild pigs in an area where they previously did not exist can be attributed to escapes of stocked animals from privately owned, “game-proof” fenced hunting preserves. In other cases, the sudden presence of wild pigs is a result of illegal translocation: the practice of capturing wild pigs, transporting them to new locations, and releasing them into the wild.

One group that continues to fuel this practice consists of irresponsible and uninformed pig-hunting enthusiasts whose goal is to establish local wild pig populations for recreational hunting. A second group comprises those whose goal is to profit from the capture and sale of wild pigs to

Wild pigs are both numerous and widespread throughout North America, with established populations in at least 36 states.



hunting enthusiasts. Wild pigs are quick to learn, and those that have been previously captured, transported to a new location, and released often are a daunting challenge to recapture. As a result, these actions contribute to the spread of this nonnative, highly invasive species.

THE NATURE OF THE BEAST: BIOLOGICAL AND BEHAVIORAL TRAITS

Pigs possess many biological and behavioral traits that enable them to live just about anywhere and quickly populate new areas.

1. Wild pigs are habitat generalists, meaning that they are highly adaptable and can live in many different habitat types throughout a landscape or region. They can tolerate a wide range of climates, ranging from the hot, dry deserts of Mexico to the subzero temperatures of the extreme northern United States and Canada.
2. Wild pigs are opportunistic omnivores.
 - They eat mostly plant matter and invertebrate animals such as worms, insects, and insect larvae.
 - When the opportunity presents itself, wild pigs will eat small mammals, the young of larger mammals, and the eggs and young of ground-nesting birds and reptiles.

U.S. Wild Pig Populations, 1988 - 2013

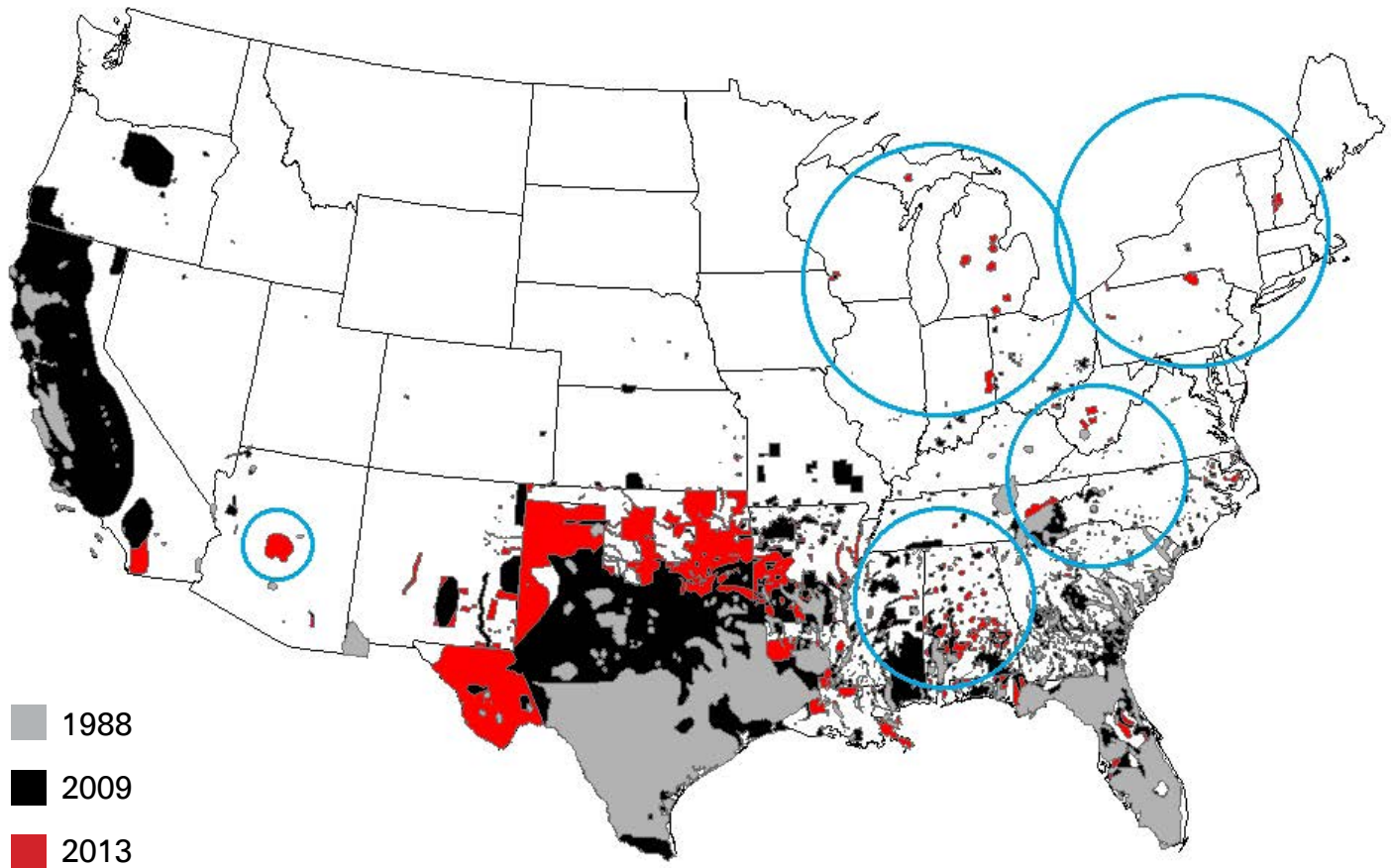

Source: Southeastern Cooperative Wildlife Disease Study, The University of Georgia, Athens, GA



1988 to 2009

118% rate of land area increase
for the conterminous United States.

That is a 5% annual increase.

2009 to 2013

34% rate of land area expansion
for the conterminous United States.

That is an 8% annual increase.

Wild pigs are numerous and widespread across the United States; shaded areas on the map represent established breeding populations. Notice the progression northward and the small, isolated populations in the far northern states, many miles from previously established populations.

Wild pigs are habitat generalists, meaning that they are highly adaptable and can live in many different habitat types throughout a landscape or region.



USDA/APHIS/Wildlife Services, Dana Johnson

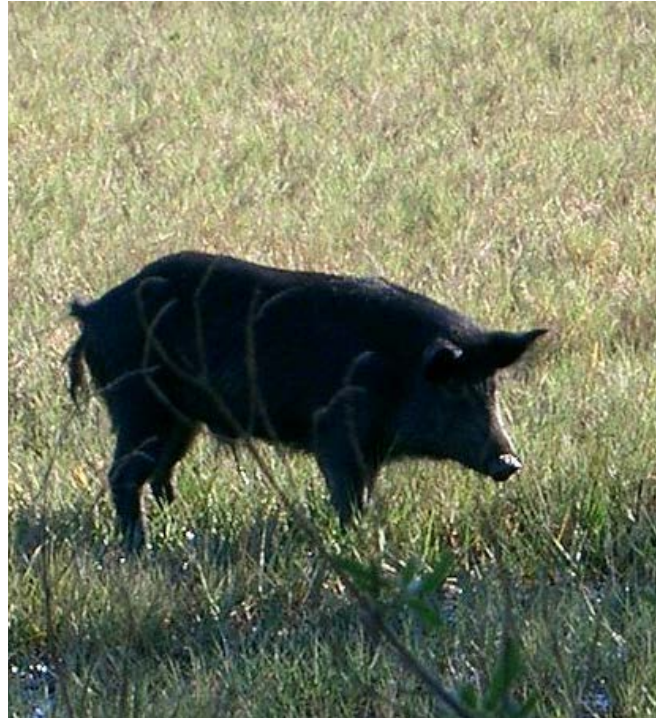

Mississippi State University Extension Service, Bill Hamrick



Texas A & M University-Kingsville, Randy DeYoung



Given food, water, and cover, wild pigs can live almost anywhere. Clockwise from top left: bottomland hardwood swamps, coastal marshes and barrier islands of the southeastern U.S., prairie and mixed forest provinces of the northern U.S. and southern Canada, and desert regions of the southwestern U.S. and Mexico.

3. Wild pigs have a high reproductive potential.
 - Some individuals reach sexual maturity as early as 6 months of age.
 - Litter sizes average about six piglets but range from three to eight piglets.
 - Females can farrow twice per year.
4. Wild pigs have low natural mortality.
 - They are most vulnerable to predation when they are young. Once pigs reach about 40 pounds, few predators pose a serious threat.
 - Although diseases and parasites have some effect on wild pig populations, their impacts are not well known and the factors involved are poorly understood.
 - The highest rates of wild pig mortality are a result of human activities: hunting, trapping, and automobile collisions.



SCWDS, Jay Cumbee

The expansion of wild pig ranges across the U.S. during the last 20 years is mostly a result of human activities, such as illegal translocation of wild pigs and escapes from fenced hunting preserves that offer wild boar hunts.

What Do Wild Pigs Eat?

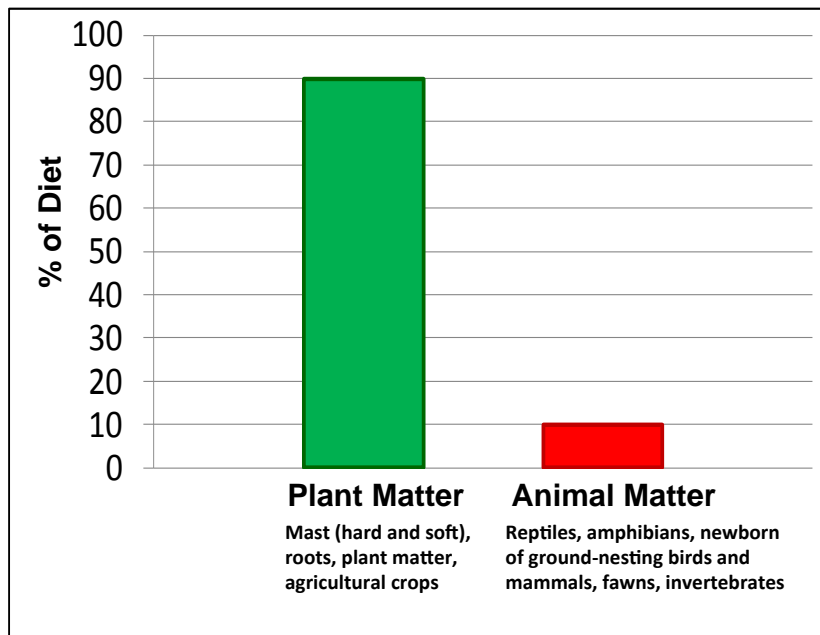

Schley, L. & Roper, T. J. (2003) Diet of Wild Boar *Sus scrofa* in Western Europe, with particular reference to consumption of agricultural crops. *Mammal Review* 33: 43-56.

Wild pigs are opportunistic omnivores. This graph shows how wild pigs can negatively impact vegetation and local fauna.

DAMAGE

Damage from pigs is nothing new, and wherever wild pigs are present, they inevitably become a problem. Although pigs were an important food source for early Americans, they also were widely considered a nuisance. Free-range livestock practices were commonplace in colonial America, and roaming pigs routinely damaged crops and food stores of both colonists and Native Americans. Thus they were a source of much tension among colonists and even more so between colonists and Native Americans.

Today, free-range livestock practices are no longer used in the eastern United States, and all free-ranging pigs are considered wild pigs. Just

Today, wild pigs are a problem for many landowners and agricultural producers.



like the free-ranging domestic pigs of early America, today's wild pigs are a problem for many landowners and agricultural producers. In addition to damaging crops and livestock, wild pigs damage forests and are a threat to native wildlife and the environment. A conservative estimate of the cost of wild pig damage and control practices in the United States for agriculture alone is \$1.5 billion annually.



Alabama DCNR, Wildlife and Freshwater Fisheries Division, Chris Jaworowski



Arkansas Game and Fish Commission, Rachel Spaulding



SCWDS, Jay Cumbee



SCWDS, Jay Cumbee and Bill Hamrick

Because of the diseases they carry, wild pigs pose a real threat to commercial swine operations. Above left: a well-worn wild pig trail leading from a nearby swamp to the feed bins of a commercial swine operation. Above right: a wild pig harvested at night beneath the feed bins of the same commercial swine facility.

AGRICULTURAL DAMAGE

- Wild pigs consume and trample crops, and their rooting and wallowing behaviors further damage crop fields. Rooting and wallowing create holes and ruts that, if unnoticed, can damage farm equipment and pose a hazard to equipment operators.
- Wild pigs may at times prey on livestock, including newborn lambs, goats, and calves. Livestock predation usually occurs on calving or lambing grounds where wild pigs may be attracted by afterbirth and fetal tissue.

FOREST DAMAGE

- Hardwood mast (for example, acorns and hickory nuts) is a major food source for wild pigs. Consequently, regenerating hardwoods from seed can be difficult in areas with high wild pig populations. In areas where mast or fruit has already germinated, rooting



Eddie Parham

Pig rubbing and scent marking behavior damages trees and leaves them vulnerable to disease and parasites.



Mississippi State University Extension Service, Bill Hamrick

Pigs are attracted to longleaf pine seedlings because the root systems are high in carbohydrates. Pigs chew the roots to extract the sap and spit out the masticated remains.

activities often dislodge and damage young seedlings

- Wild pigs can damage pine plantations and natural regeneration areas through direct consumption, rooting, and trampling. Longleaf pine (*Pinus palustris*) seedlings in particular are favored by wild pigs because the soft root systems are high in carbohydrates.
- Wild pigs can damage both pine and hardwood trees by using them as scratching posts. Intense rubbing and damage to the bark layers can leave trees more vulnerable to harmful insects and pathogens (bacteria, fungi, and viruses).

THREATS TO NATIVE WILDLIFE

- Wild pigs compete for food and space with native wildlife species, especially game animals such as deer, turkey, and quail.
- Wild pigs can be significant predators of eggs and newly hatched young of ground-



Mississippi State University Extension Service, Bill Hamrick

Wild pigs are fierce competitors with native wildlife species for food resources such as hard mast.

nesting birds and sea turtles, small mammals, salamanders, frogs, crabs, mussels, and snakes. Though not considered a significant predator of white-tailed deer fawns, wild pigs do sometimes kill and eat newborns.

- Wild pig rooting, wallowing, and trampling damage native plant communities that provide habitat and food sources for native wildlife species.

ENVIRONMENTAL DAMAGE

- Rooting, wallowing, and trampling activities compact soils, which in turn disrupts water infiltration and nutrient cycling. Also, these soil disturbances contribute to the spread of invasive plant species, which typically favor disturbed areas and colonize them more quickly than many native plants.
- Wild pig activity in streams reduces water quality by increasing turbidity (excessive silt and particle suspension) and bacterial contamination. In time, turbidity and added



Westervelt Ecological Services, John McGuire

Wild pigs threaten ecologically sensitive communities such as the pine flatwoods of the Lower Coastal Plain of the southeastern U.S.



Eddie Parham

Wild pig activities in streams and other waterways can greatly diminish water quality.

contaminants affect a variety of native aquatic life, most notably fish, freshwater mussels, amphibians, and insect larvae. In some streams, feces from wild pigs have increased fecal coliform concentrations to levels exceeding human health standards.

- Destruction of vegetation in freshwater and brackish marshes not only reduces aquatic life and water quality but also affects ecosystem services, such as water filtration, flood control, and storm surge protection.

LEARN TO RECOGNIZE THE SIGNS

Sometimes landowners do not realize they have pigs on their property until they actually see a pig or until the damage is widespread. The earlier the presence of wild pigs is detected and control measures begun, the better. Some telltale signs that wild pigs have moved into an area include tracks, rooting, wallows, nests or beds, and tree and post rubs.



Mississippi Levee Board

Pig rooting along levees, roadsides, and other thoroughfares can lead to costly infrastructure repair, equipment damage, and public safety concerns.

Wild pigs leave field signs that are unique and identifiable, making it relatively easy to determine whether wild pigs inhabit an area.



Mississippi State University Extension Service, Bill Hamrick

Rooting



Mississippi State University Extension Service, Bill Hamrick

Wallow



Mississippi State University Extension Service, Bill Hamrick

Wallow and tree rub



Mississippi State University Extension Service, Bill Hamrick

Utility pole rub



Mississippi State University Extension Service, Bill Hamrick

Wild pig nest



Mississippi State University Extension Service, Bill Hamrick

Wild pig track



Mississippi State University Extension Service, Bill Hamrick

Wild piglet track



Mississippi State University Extension Service, Bill Hamrick

Deer track

WILD PIGS AND DISEASE

Wild pigs are known carriers of at least 45 different parasites (external and internal) and diseases (bacterial and viral) that pose a threat to livestock, pets, wildlife, and in some cases, human health. The risk of being infected by one of these diseases is real: in 2007, Florida health officials documented that 8 of 10 human cases of swine brucellosis were linked to wild pig hunting activities. Many of these diseases are transmitted through contact with bodily fluids and handling or ingestion of infected tissues. Diseases can also be transmitted indirectly through ticks or contaminated water sources. For more information on wild pig diseases, see page 31.

DISEASE PREVENTION

Follow these simple measures to avoid infection when handling or field dressing wild pigs:

- Wear latex or nitrile gloves; pathogens can enter the body through cuts on hands or torn cuticles.
- Avoid splashing body fluids into your eyes or mouth.
- Follow correct refrigeration, freezing, and cooking methods. Freezing to 0°F will render bacteria inactive but will not destroy them; once thawed, bacteria can again become active. You should not rely on home freezing to destroy *Trichina* and other parasites. Thorough cooking will destroy all parasites. Cook meat until internal juices run clear or until it has reached an internal temperature of 170°F.
- Wash your hands thoroughly after field dressing and processing meat, even if you wear gloves.

Wild pigs are known carriers of at least 45 different parasites and diseases.



USDA-Wildlife Services, Cal Betsill

Wearing latex or nitrile gloves will reduce your chances of potential disease risks associated with handling wild pigs.

- Thoroughly clean and disinfect work areas and tools used to dress and butcher wild pigs.
- Dispose of animal remains, used gloves, and other materials properly. Animal remains should not be left for scavengers, nor should they be fed to dogs. Depending upon your jurisdiction, several methods of appropriate disposal may be considered. Check with your local health department or state wildlife agency.



Sherman "Skip" Jack
*Professor of Veterinary
 Pathology*

*Mississippi State
 University College of
 Veterinary Medicine*

DISEASE IMPACTS OF WILD PIGS

Diseases of wild pigs affect humans and other animals in several ways. First, there are diseases that are transmissible to humans, called zoonotic diseases. Then there are diseases that might impact livestock and pets (for example, swine, cattle, and dogs). A third group of diseases are foreign animal diseases (FADs), those that have never been present in North America or those that were present at one time but have been eradicated during the last 100 years. (Examples are foot-and-mouth disease and hog cholera, or classical swine fever.) While not a direct threat to human health, FADs would have overwhelming economic impact if introduced—or reintroduced—and perhaps never again could be eradicated from our continent because of the continued expansion of wild pig ranges.

Foreign Animal Diseases & Pseudorabies

Foreign animal diseases include a number of conditions that have never been identified in North America or have been eradicated during the past century. Some of these diseases affect only swine (for example, hog cholera, or classical swine fever, and African swine fever), but others affect multiple species such as foot-and-mouth disease, which can affect cloven-hooved animals like cattle, deer, and elk. Both hog cholera and foot-and-mouth disease were eradicated from the United States during the previous century (hog cholera during the 1970s, foot-and-mouth disease in the early 1900s). However, eradication occurred before wild pigs were found in most of the lower 48 states, and even

then the cost was in the billions of dollars. Thus, reintroduction of those diseases today would have a greater host population in which to spread and would be much more costly, if not impossible, to eradicate again.

Pseudorabies virus (PRV), while not foreign, is another disease with implications for nonswine animals such as cattle, sheep, and dogs. This disease is a herpes virus and is not related to rabies. Some symptoms of the disease may resemble rabies, thus the term *pseudorabies*. It sometimes kills pigs but is routinely fatal in nonswine species that become infected either through direct contact or ingestion of tissues from PRV-positive wild pigs. Pseudorabies is a reportable disease and may restrict transporting animals (even uninfected ones) across state lines. Thus the economic impact may extend well beyond affected animals or affected premises. See page 31 for more information on common diseases among wild pigs.



Bacteria (*Staphylococcus*)

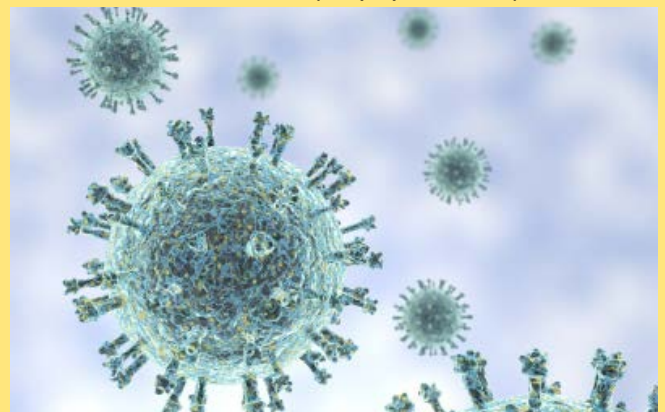

Virus (Swine influenza)

Wild pigs are known carriers of bacterial and viral diseases that are a threat to livestock, wildlife, pets, and, in some cases, human health.

MANAGEMENT

Wild pig populations can be managed by lethal or nonlethal methods. Nonlethal methods include installing fencing to exclude pigs, using guard animals to protect livestock, and vaccinating animals to prevent disease spread. Although in some situations nonlethal methods are appropriate and effective, in many cases they are not a good option, either because they do not work well or are too expensive. Therefore, lethal methods are often the most practical and widely used. They include trapping, shooting, and hunting with dogs. Currently, there are no toxicants registered for use on wild pigs in the United States, so poisoning is not an option.

Hunting and trapping regulations vary by state. Be sure to check the hunting and trapping regulations specific to your area or contact your local conservation officer before beginning any wild pig trapping and removal program in an area.

TRAPPING WILD PIGS

Trapping is the most efficient means for removing wild pigs because it is a continuous activity requiring far less time and effort than other methods such as hunting. Successful pig trapping hinges upon several key components:

- locating high-use areas for potential trap sites and attracting pigs to these locations
- conditioning pigs to the trap enclosure
- effective trap design and size
- patience

Currently, there are no toxicants registered for use on wild pigs in the United States.



Alabama DCNR, Wildlife and Freshwater Fisheries Division, Chris Jaworowski



Wild pigs do not acknowledge boundaries and land lines. Therefore, a cooperative trapping effort with adjoining landowners will prove more successful than conducting a trapping program on your own.

Scouting the Trap Location

Once you discover wild pigs have moved onto your property, do not immediately build a trap and set it to catch. Instead, first scout the property and identify their travel routes and any other areas of recent activity—bedding and loafing areas, mud wallows—and establish nearby bait sites to attract pigs from the surrounding area. Depending on the size of your property and the distance between areas with recent pig activity, you may want to establish several of these bait sites. A good rule of thumb is to establish a bait site every 100 to 200 acres across a property. Here are several factors to consider when choosing a bait site:

- Level ground with enough open to semi-open area to allow for building a four- to six-panel corral trap if pigs should begin using the site.
- Shade (full or partial); during warm months, a captured pig in the shade is less stressed and less likely to heavily damage a trap trying to escape.
- Vehicle access close to the site saves time and labor in constructing, baiting, and checking the trap, and also in removing pig carcasses from the trap.

It is usually best to begin baiting wild pigs with whole-kernel dried, shelled corn. It is readily available at local feed and seed stores, is easy to work with (there is no excessive odor or mess as with fermented corn), and, more often than not, it does a good job of attracting wild pigs. If it becomes clear that pigs are visiting your bait site but not readily consuming the dry corn, experiment with fermented corn or other types of bait and/or attractants.

There are several different methods you can use to bait your scouting sites. The simplest of these is to scatter 1-2 gallons of corn on the ground in an area 8-10 feet in diameter. While this is a “tried and true” method for baiting wild pigs, there are a couple of downsides: (1) Bait on the ground for longer periods of time is more

susceptible to becoming toxic (aflatoxins) and/or being consumed by nontarget species such as deer, turkey, and raccoons; and (2) You have to check the sites daily in case the corn needs to be replenished.

The “bait bucket” is another method that is sometimes used for baiting wild pigs. A bait bucket is simply a 5-gallon plastic bucket half filled with corn and covered in water and tied or strapped to the base of a tree. While this method will greatly reduce the amount of bait consumed by nontarget species, you either need access to a nearby water source or you will have to transport water to the site. Bait buckets can be checked every few days to determine if pigs are using them.

The most convenient method for baiting wild pigs is to set up an automatic spin-cast feeder at each site, programmed to dispense corn at a regular time each day. In doing so, you can reduce your site visits to every 2 or 3 days instead of every day. While this method requires more startup costs, purchasing several feeders is a good investment if you think you are going to be dealing with wild pig problems for a few years. It’s a big help to have at least one feeder for each trap you build. There are many different brands and styles of automatic spin-cast feeders available, but you can purchase a serviceable feeder for \$50 to \$100.

When scouting trap locations, it is a good idea to monitor each bait site with a digital game camera to confirm whether or not pigs are using the bait site. In addition, game camera photographs will show you how many different groups of pigs are on the property and the number of pigs you will need to remove.

Game laws regarding the use of bait vary between states. Before you bait any pigs or pig traps, be sure to check the baiting regulations specific to the state in which you will be conducting these activities.



When using a tripod-style automatic feeder, wiring each leg of the feeder to a steel T-post driven into the ground next to it will prevent large pigs from tipping over and damaging your feeder.



Mississippi State University Extension Service, Bill Hamrick

A spin-cast feeder and game camera can save you considerable time and effort by reducing the frequency of your visits to scouting and trap sites.

Conditioning Pigs to the Trap

Conditioning pigs to the trap is probably the most important component to successful pig trapping. Once you have identified an active location, set up a trap and begin the conditioning process by baiting only inside the trap enclosure. The goal is to get all of the pigs in a sounder or family group to trust they can enter and leave the trap enclosure at will.

Sometimes 1-2 weeks of conditioning is necessary before an entire sounder will enter the trap enclosure. Some pigs in a sounder (mostly adults) initially do not feel comfortable entering a trap and will stay outside while others (mostly

juveniles) readily enter and feed on the bait. Therefore, it is important to be patient and allow all of the pigs to become conditioned to routinely entering the trap to feed and leaving unharmed before you set it to catch. Continuing to monitor your trap(s) with a game camera during this phase will take the guesswork out of when to set the trap. See "Using Remote-Sensing Cameras to Enhance Wild Pig Trapping Efficiency." Also, see Appendix V for suggestion on how to position game cameras when monitoring a pig trap.

Be aware that sometimes 2 weeks may pass and one or two pigs just will not enter the trap. This trap-shyness is most often seen in older pigs and pigs that have had a previous bad experience with traps (they were captured and translocated or shot at while inside or near a trap). In such cases, you will have to decide whether or not to go ahead and set the trap to catch and try to remove trap-shy pigs by other means at a later date.

During the conditioning phase, tie the trap door securely open to prevent premature captures of wild pigs and allow them continual access to the bait. Do not bait outside the trap—force the pigs to enter the enclosure to get fed. In the beginning, you may have to place some bait on the ground just inside the trap entrance to entice pigs to enter. However, as the conditioning phase continues, you should place the bait farther inside the enclosure.

Once pigs are "on the bait," be sure to maintain a constant supply inside the trap so they have something to eat each time they visit the

When dealing with trap-shy pigs, you may need to remove the door from the trap and create a larger opening until they become used to regularly entering and leaving the trap. Also, a larger trap may appear less confining to trap-shy pigs.



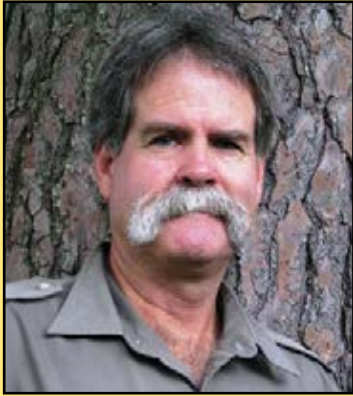

Billy Higginbotham
*Professor and Extension
 Wildlife & Fisheries
 Specialist*
*Texas AgriLife
 Extension Service*

USING REMOTE-SENSING CAMERAS TO ENHANCE WILD PIG TRAPPING EFFICIENCY

For those areas where wild pigs have not had negative encounters with humans or where little or no trapping has been done, you can get away with a lot. However, try those same techniques with pigs that have been hunted, dogged, and— heaven forbid, trapped and released—and you’re dealing with what amounts to a completely different animal. So how can landowners stack the odds in their favor when dealing with this super intelligent animal? Using a remote-sensing camera throughout the prebaiting period not only eases the task at hand but also provides helpful information that will increase your pig trapping success.

You can make on-site observations of bait consumption and check for other signs such as tracks, but having a camera recording around the clock to monitor wild pig response to prebaiting is a big help. Trapping wild pigs is a process, not an event, and in addition to confirming pig response to prebaiting efforts, the camera will also reveal the approximate number of pigs in the sounder. This information speaks volumes as to the size of trap that will be needed to do the job. Also, most cameras record the dates and times of events, and

it’s sometimes helpful to know just when those visits occur.

The question I’m always asked about cameras is whether models with infrared features are necessary to avoid spooking the pigs with a flash. In my experience, the flash is not a deterrent on the larger traps that I employ. However, on a smaller trap, the camera should be positioned a comfortable distance away, yet close enough to be triggered reliably and capture the action.

Because a picture is worth a thousand words, the camera should continue to record during the actual trapping phase. Were you successful in capturing the entire sounder? If not, were some pigs still outside when the gate was tripped, or were they absent that particular night? Did any pigs escape from the trap? If so, how did they do it? Photographs can provide good information that will help you to be a more effective pig trapper. Using remote-sensing cameras set in the right location, plus patience on your part, make for a successful pig trapping formula. See Appendix V for game camera setup and positioning.



Trail cameras are the best tool for monitoring wild pig activity during the trapping process.



Mississippi Department of Wildlife, Fisheries, and Parks.

Conditioning pigs to the trap before setting it to catch can greatly improve capture success.

site. If you are conditioning pigs to a corral trap enclosure, the use of an automatic spin-cast feeder set to dispense corn for 8-10 seconds once a day will reduce the amount of time and effort needed to keep the trap baited and will minimize human disturbance to the area.

Baiting and Setting the Trap

Once you have game camera evidence that all pigs in a sounder are routinely entering the trap to feed, it is time to make a set. If using conventional trigger mechanisms, bait placement within the trap is a very important detail of pig trapping. Do not place bait near the trap entrance, and do not bait heavily around the trigger mechanism. Instead, spread corn in a shallow pile about 2-3 feet in length along the sides of the enclosure. Place only about a half-gallon of corn over the root stick or behind the trip wire. The object is to buy more time for all of the pigs to enter the trap and draw them away from the door before it is triggered. Using this strategy can increase trapping success rates from one or two animals to 10 or more. See Appendix V for an illustrated baiting strategy.

Once the trap is set, be sure to check it daily, preferably in early to mid-morning. Leaving captured pigs in a trap for extended periods of

time without food and water is inhumane and may even result in fines in some states. Also, the more time a stressed pig remains in a trap, the more time it has to damage the trap and/or trap door and possibly escape.

Types of Pig Traps

There are three main types of wild pig traps: box traps, cage traps, and corral traps. Traps may be constructed from steel or wood and typically are rectangular or round. Though some experienced pig trappers have individual preferences, a trap of adequate size in any of those shapes is effective in capturing pigs if the trapping process is properly executed.

Trap efficiency is important, so keep in mind that catch size is a limiting factor with certain types of traps. Factors to consider when selecting the type of pig trap that will best meet your needs are

- sounder size
- affordability
- weight and portability
- presence and numbers of nontarget species such as deer or black bear

Box Traps

Box traps are rectangular or square structures made of wood fence panels constructed from 2-by-4-inch and 1-by-4-inch or 1-by-6-inch boards. The most common box trap design is 4 feet wide, 8 feet long, and 5 feet high with no fixed top or bottom. (A top is not necessary because the 5-foot-high side panels prevent most pigs from climbing out).

The trap is usually equipped with a single-catch wooden drop door, but it also can be equipped with a multicatch trap door, such as the saloon-style door. Box traps are heavy enough that pigs usually are unable to root under the sides and use their head to lift the trap and escape. However, it is still best to secure box traps by driving a steel T-post into the ground at opposite front and back corners and fastening the trap sides to the T-posts with wire.



Mississippi State University Extension Service, Bill Hamrick

A 4-by-8-by-5-foot box trap fitted with a guillotine or drop-style wooden door.

The box trap can be transported in panels and assembled on location using 3-inch exterior decking screws (nails are not recommended).

Cage Traps

Cage traps are constructed from heavy-gauge wire livestock panels welded to a steel angle iron or square tubing frame. The most common cage trap design is a rectangular enclosure ranging in size from 4 feet high, 6 feet long, and 4 feet wide to 5 feet high, 12 feet long, and 4 feet wide.



The terms *box trap* and *cage trap* often are used interchangeably when referring to any square or rectangular trap. However, in this publication they are classified as two different trap types.

A more recent design is a circular cage trap with wire livestock panels welded to a round steel frame (similar to livestock hay rings). The advantage of this design is its portability; it can be rolled onto a trailer or rolled along the ground. Another design is similar to the box trap and is made of wire livestock panels welded to individual steel frames and fastened together with pins or bolts.

Commercially available cage traps often have both a top (overhead) and bottom (floor) panel and are equipped with a spring-loaded, single-catch or multicatch trap door at one end of the cage.



Texas A&M-Kingsville, Randy DeYoung

Cage trap.



Randy Kelley

Round cage trap.

Cage traps less than 5 feet tall should include a top panel to prevent pigs from escaping over the sides. Bottom or floor panels are not necessary for well-built cage traps. In fact, many experienced pig trappers recommend not using floor panels. Their reasoning is that most pigs do not like the feel of the wire panel underfoot and will balk at fully entering the trap.

To prevent large pigs caught in this type of trap from lifting the trap and escaping underneath the side panels, wire the trap to T-posts driven into the ground at opposite front and back corners or on opposite sides of a round cage trap.

Corral Traps

The most common type of corral trap is a circular enclosure constructed from 16-by-5-foot welded wire livestock panels—no larger than 4-by-4-inch openings—fastened to steel T-posts with U-bolts or heavy-gauge wire. The lack of corners provides added strength and prevents captured pigs from piling into corners and climbing over one another to escape over the top. Also, the open-topped corral allows non-target species to escape over the top of the trap.

Corral traps are quick and easy to build—a two-man crew can erect an enclosure in less than 1 hour—and are easily expanded by adding more livestock panels as needed. In addition, the materials needed to construct a four- to six-panel corral trap are usually less expensive than smaller, prefabricated traps.

What Is the Appropriate Size for a Corral Trap?

An appropriately sized trap is one that encompasses enough area to capture in a single event the entire sounder or group of pigs targeted for removal. In addition to being sufficient to hold a certain number of pigs, the object of trap size is to build it large enough so that

- it is less confining and allows pigs to spread out and feed within the enclosure; and
- the distance from the entrance to the trigger mechanism buys more time for all of the pigs to enter before the trap is sprung.

The following are some suggested corral trap sizes in relation to wild pig sounder sizes. Trap sizes are minimal and are merely suggestions. They are not science-based, but based on observations and first-hand accounts from trapping and natural resource professionals.

Sounder Size	Livestock Panels (16 feet)	Corral Diameter
14 (2-3 adults and juveniles)	4	19.5 feet
15-20 (3-4 adults and juveniles)	6	29 feet

Building a Circular Corral Trap

In addition to the following steps for building a circular corral trap, see the corral trap diagram in Appendix II.

1. Set the trap door in place and drive a T-post firmly into the ground on each side of the door. Be sure the studded sides of the T-posts are facing the inside of the trap and the posts fit snug against each side of the trap door. Fasten the door to the T-posts using heavy-gauge wire.
2. Position a livestock panel on each side of the door so that the panel ends and door frame meet. Be sure the horizontal strands of the livestock panels are on the inside of the trap and panel ends are positioned on the inside of the T-posts (against the studded sides). Secure the panel ends to the T-posts on each side of the door using three U-bolts.



Alabama DCNR, Wildlife and Freshwater Fisheries Division, Chris Jaworowski

Corral trap with a guillotine or drop-style wooden door.



Natural Resources Media & Nature Videography, Rex Allen Jones

Corral trap with a rooster-style trap door.

3. Working from the free ends of the panels on each side of the trap door, connect the remaining panels to one another by overlapping the adjoining ends 8-12 inches and securing the sections together using five-eighths-inch cable clamps or heavy-gauge wire. Complete the circle and “fine tune” the corral’s shape by pulling or pushing the joined panels in or out as necessary.
4. Finish the trap by working your way around the outside of the corral and driving a steel T-post in the ground at the middle of each overlapped panel section and at the middle of each panel—be sure the wire panels fit snug against the T-posts. Include one or two additional T-posts driven into the ground on each side of the trap door to strengthen the trap. (Game camera footage of captured pigs suggests they tend to focus most of their escape efforts at or alongside the trap door.)
5. Fasten the livestock panels to the T-posts; use two U-bolts per post, one at the bottom of the panel about 12 inches from the ground and one below the top strand of the panel. If using heavy-gauge wire to fasten the livestock panels to the T-posts, use at least four wire fasteners beginning 6 inches from the ground and evenly spaced along each T-post to the top strand of the panel.

Livestock panels used in constructing wild pig traps should be of at least 4-gauge size and no less than 5 feet high. Though it is not impossible, only the rarest of pigs can jump a 5-foot-tall panel. A mesh size of 4 inches square or smaller will prevent small pigs from escaping through the panels.



Pros and Cons of Trap Types

Type of Trap	Pros	Cons
Box Trap	<ul style="list-style-type: none"> • easy to construct • cheaper than commercial steel traps • requires less space for transport and storage • quick setup with wood screws and a cordless drill 	<ul style="list-style-type: none"> • catch size/trapping effort limited • wood panels appear more confining than wire panels • wood requires more long-term maintenance than wire panels • difficult for one person to transport and set up
Cage Trap	<ul style="list-style-type: none"> • wire panels appear more open and less confining to pigs • easy one-person transport and setup 	<ul style="list-style-type: none"> • catch size/trapping effort limited • overhead panels prevent most nontarget species from escaping
Corral Trap	<ul style="list-style-type: none"> • trap size easily adjusted for larger sounders • open top allows for escape of nontarget species • trap appearance and open top may appear less confining to pigs 	<ul style="list-style-type: none"> • requires more setup time than cage or box traps • livestock panels may need to be cut in half for transport • tree roots in wooded areas can pose a problem for driving and pulling T-posts

Trap Door Designs

Single-Catch Trap Doors

Guillotine or drop-style doors are characterized as “single-catch” doors because once the trap has been sprung and the door falls closed, no more animals can enter the trap until it is manually reset. The simplest and least expensive version of the single-catch doors is the wooden drop door constructed from 2-inch-by-4-inch and 2-inch-by-2-inch lumber and ¾-inch-thick plywood. Single-catch trap doors may also be constructed from steel. Steel drop doors are heavier and more difficult for one person to handle, but the steel construction allows for a wider door opening than wooden drop doors. While not scientifically proven, observations from the field seem to suggest that pigs more readily enter a trap through a 5-foot to 8-foot-wide door versus a smaller opening. Regardless of which drop door design is used, with proper prebaiting and game camera footage to help you decide when to set the trap,

these doors can be very effective for trapping pigs. The simplest and least expensive type of trap door used for trapping wild pigs is the guillotine or sliding drop-style door. See single-catch trap door plans and specifications in Appendix III.

Multicatch Trap Doors

Root doors and spring-loaded doors are characterized as “multicatch” doors because they are designed to allow additional animals to push through the doors and enter the trap once it has been sprung. There are several variations in terms of structural design and materials used for both root doors and spring-loaded doors; doors are most often constructed from either steel “angle iron” or steel tubing (square or circular) or a combination of the two. While these trap doors can be effective for capturing pigs inside the trap when it is sprung, there is little evidence to prove that additional captures occur after the doors have closed. See multicatch trap door plans and specifications in Appendix III.

There are many different trap door designs. The type of door you use depends on budget and ease of transport.



Alabama DCNR, Wildlife and Freshwater Fisheries Division, Chris Jaworowski



Alabama DCNR, Wildlife and Freshwater Fisheries Division, Chris Jaworowski

Guillotine or drop-style trap doors are commonly constructed from lumber but can also be constructed from steel.



Mississippi State University Extension Service, Bill Hamrick



Mississippi State University Extension Service, Bill Hamrick

Once triggered and shut, the saloon or butterfly-style trap door allows pigs outside the trap to push in and enter the trap, but they cannot push out and exit the trap. If using a trap door less than 5 feet in height, use a piece of steel mesh panel to account for the difference in space between the top of the door and the top of the trap sides.



Scott Alls

USDA/APHIS/Wildlife
Services



Dana Johnson

USDA/APHIS/Wildlife
Services

DECOYING WILD PIGS

When using conventional triggering methods to trap wild pigs, you have no control over when pigs engage the trigger mechanism to spring the trap. Even if you use large corral traps and bait the trap strategically, there are no guarantees you will have 100 percent capture success when the trap door closes. So what should you do when you do not capture an entire group or sounder of pigs you have targeted for removal? Probably the best option is to dispatch and remove the ones you did capture and set the trap again to capture the rest of the group. However, there is still another option that has been used with some amount of success: use the pigs you did capture as decoys to help you catch the ones you missed.

Game camera footage has shown that, when a partial sounder of pigs is captured, the ones you missed often return to the trap on a nightly basis to “visit” their captured family members. It also has shown that the presence of pigs in an enclosure next to an open trap seems reassuring to other pigs that it is okay to enter the trap. Furthermore, game camera footage has shown some trap-shy pigs that would not enter a trap during the first trapping process entering the enclosure and feeding the first night it was baited and set to catch again.

To construct a decoy pen, use two to three extra livestock panels and build an adjoining decoy pen to the existing trap enclosure. Begin and end the decoy pen at one of the overlapped sections of livestock panels on the corral trap. Next, loosen and open the

two overlapped livestock panels and herd the pigs into the decoy pen.

Another option is to leave the pigs inside the corral trap and set portable cage traps on each side of the corral. You can even set two cage traps next to one another and use one as a decoy pen. When decoying pigs, be sure to supply the pigs you have already captured (the decoys) with water and feed, and make sure they are provided some shade. You want them to be content and happy, not stressed and acting like they are actually trapped.

Although using decoy pigs is not 100 percent foolproof, it has proven more successful than not. Trapping wild pigs can be frustrating, so there is always room for a new trick in the bag. If you are trapping pigs and find yourself in this situation, you may want to give the decoy pigs a try.



USDA/APHIS-Wildlife Services

Above: A group of juvenile pigs captured the first night of a trapping effort. Below: Adult and sub-adult members of a wild pig sounder captured in an adjoining trap the following night.



USDA/APHIS-Wildlife Services

When first setting the saloon-style trap door, prop the doors open with the triggering mechanism and drive a stake into the ground behind both doors. This technique prevents pigs that make their turn too soon when entering the trap from pushing one door farther open and springing the trap.



Mississippi State University Extension Service, Bill Hamrick

Placement of stakes behind each door panel on the inside of the trap.



Mississippi State University Extension Service, Bill Hamrick

Rooter-style trap doors can be constructed from either steel or aluminum. The door contains three separate panels. Once the trap has tripped (1) three separate panels make it easier for pigs to push open versus one solid panel and (2) it reduces the chance for already captured pigs to escape while other pigs enter.

Trigger Mechanisms

A variety of trigger mechanisms can be used when trapping wild pigs, but probably the two most common of these are the root stick and the trip wire.

The Root Stick

The root stick is a simple trigger mechanism consisting of two sections of concrete reinforcing bar (rebar) or two sticks, called set stakes, driven into the ground at a 45- to 60-degree angle—with the ends pointing away from the trap door (Appendix IV). A length of rope or cord is attached at one end to the drop door and at the other end to the middle section of a strong stick or piece of scrap lumber, called the root stick. The door is lifted and held open by wedging the root stick behind the holding stakes. Bait is placed around and on top of the root stick, and the trap is sprung when pigs feeding on the bait “root” the stick out from behind the holding stakes. The root stick works best when used with a sliding drop door.



Alabama DCNR, Wildlife and Freshwater Fisheries Division, Chris Jaworowski

Root stick.

Depending on the trigger mechanism used, nontarget species such as raccoons can reduce success rates with single-catch trap doors. See *Trip Wires Versus Root Sticks.*

The Trip Wire

The trip wire is a continuous line or wire strung 16-20 inches above the ground across the rear section of the trap, up the side of the trap and across its top span, and attached to a release mechanism (pin, hook, or prop stick) on the trap door (Appendix IV). Bait is placed behind the trip wire, and, when pigs walk into it, the pressure exerted against the wire pulls the release mechanism from its set position and closes the door. The amount of pressure required to spring the trap can be adjusted by increasing or decreasing the tension on the trip wire.

Because of the varying levels of trigger sensitivity, there are times when it may be more tactical to use a trip wire instead of a root stick with a drop door. Root sticks are less sensitive to disturbance, and, if pigs seem to be purposefully avoiding the root stick trigger (eating all of the bait except for that around the root stick) or soils are too loose or too compacted to use a root stick,

then a trip wire is the better option. Root stick triggers can be converted to work with a trip wire in just a few simple steps (Appendix IV).

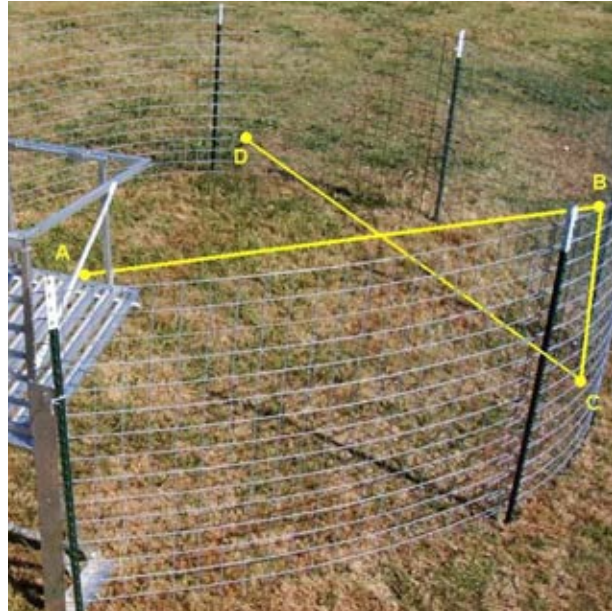

Mississippi State University Extension Service, Bill Hamrick

Trip wire.

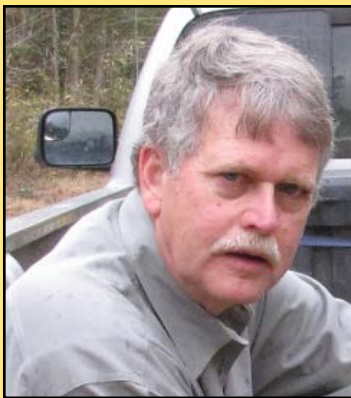

Carl Betsill
North Carolina
Wildlife Disease
Biologist, Retired
USDA/APHIS/Wildlife
Services

TRIP WIRES VERSUS ROOT STICKS

When I first began trapping wild pigs, I was a firm believer in using a root stick to trigger the trap door. My theory at the time was that pigs are very aggressive eaters, and a root stick will provide time for all the pigs to enter the trap before the trigger mechanism is tripped and the door drops. Observing traps with trail cameras has caused me to reevaluate my thinking.

I was surprised to find that pigs were entering my trap, eating a couple of bites of corn from

around the root stick, and leaving. With leaf litter on the ground, there was often no sign that pigs had been there. When the root stick did work, it was not always from rooting but was simply triggered by chance—the pigs hit the rope with their backs. The trail camera video often revealed pigs entering and leaving over a period of up to 2 hours before triggering the trap door.

For this reason, I now favor the trip wire. It can be set high enough to avoid small pigs, raccoons, and opossums but still low enough to be tripped by shoat and adult pigs. With proper bait placement, multiple captures are still possible.

While I have not broken my record of 19 pigs in one trap with a root stick, I commonly get 6 to 9 pigs even with the trip wire. I still use the root stick, especially in areas where I'm plagued with deer visits, but after observing that pigs can sometimes be "dainty" eaters, I certainly don't use it as much.

HIGH-TECH PIG TRAPPING

In recent years, several U.S. companies have integrated short message service (SMS) and live video technology with wild pig trapping to develop several types of remotely activated trap doors or gates. These gates rely on a remote sensing camera—very much like a game camera—that records pictures or video of pigs (or nontarget animals) inside the trap or moving about near the outside of the trap. The camera sends real-time pictures or video to a person's smartphone or email address.



During the prebaiting phase, the user can remotely monitor multiple bait sites and gather information such as the total number of pigs in the sounder, number of juveniles and adults, feeding times, and travel directions without leaving their home or office. This information is important to determine the necessary trap enclosure size and the best location to position the gate.

Once the trap enclosure is constructed, the user can employ this same technology to monitor the trap and decide when to close the gate—when real-time photos or video show the entire sounder is inside the enclosure. The user can then trigger the gate closed with a single text code sent to the camera.



Because of the technological component, these gates are more expensive than traditional trap doors. Also, trapping location may sometimes be a limiting factor depending on distance from cellular towers and signal strength. However,

when employed in areas with adequate signal strength, these technologically advanced gates can reduce both time and fuel expense for trappers and greatly increase the chances of capturing the entire sounder in a single trapping event.



FIVE STEPS FOR SYSTEMATIC WILD PIG REMOVAL

Step 1: Locate

Before setting up a trap, invest some time scouting the property for potential pig trapping sites. On small properties, this may be as simple as walking around locating high-use areas of wild pig activity and establishing bait sites in these high-use areas. For larger properties, it may be necessary to establish bait sites with game cameras every 100-200 acres to determine if wild pigs are in the vicinity.

Step 2: Identify

Monitor each bait site with a digital game camera. Game camera photographs will confirm that pigs and not some other species are using the bait. They also will help you identify how many pigs are in the area and how many you will need to remove.

Step 3: Condition

At bait sites where wild pigs have been identified and are routinely visiting, continue providing bait. However, on other bait sites that were used to scout for/locate pigs that had no wild pig activity, bait may be discontinued. Build or set up your trap and begin conditioning the pigs to enter and leave the trap enclosure. Be sure the trap door is securely tied or propped open, and bait only inside

the enclosure. Monitor the trap with a game camera—only when all of the pigs are routinely entering the enclosure to feed should you move on to the trapping step. Patience is of utmost importance at this stage of the process.

Step 4: Trap

Depending on the number of wild pigs using the property, it may take one or several trapping events to capture all of the ones you were able to identify in Step 2. You should have a rough estimate of the numbers of pigs out there, so keep trapping until you remove them all. This is where perseverance comes into play because any pigs you do not remove will continue to cause damage and most likely reproduce and repopulate the property.

Step 5: Monitor

Follow-up monitoring is an important part of staying on top of wild pig problems. Removing pigs from one property can create a vacuum for pigs from surrounding areas to expand their range and fill the void. So maintain a watchful eye and, at the first signs of wild pigs moving onto the property again, repeat the five-step process. Wild pig populations and the property damage they cause are easier to keep under control when you get to them early and before they begin multiplying!



SNARING WILD PIGS

The use of steel cable snares to capture wild pigs can be very effective. However, they pose a greater risk than other methods for capturing nontarget wildlife species (such as bear, deer, and turkey) as well as domestic animals (such as calves, sheep, goats, and dogs). For this reason, it is illegal to use snares in some states. In those states where snares are legal, natural resource agencies often discourage their use except when used by a trapping professional.

EUTHANIZING WILD PIGS

Although pigs are a nuisance or pest species, they are wild animals, and appropriate measures should be taken to minimize stress to the animal and ensure that they are dispatched humanely. Pigs can be easily dispatched using a firearm chambered for .22 long rifle or larger calibers fired precisely into the brain cavity. The brain shot will ensure a quick, humane death while minimizing the amount of blood left in the trap. A shot placed about 2 to 3 inches above an imaginary line directly between the eyes, or at the midpoint of an imaginary line between the eye and ear, will effectively penetrate the brain cavity. Be careful not to shoot pigs directly between the eyes as this area is the beginning of the nasal cavity.

If euthanizing wild pigs with a rifle, do not insert the rifle barrel through the side panels in an effort to avoid accidentally shooting the trap. Pigs commonly will charge and ram into the side of the trap trying to find a way out. If a pig happens



Adult wild pigs are quite strong and can be aggressive, so exercise caution when approaching a trap. Approach the trap slowly and whenever possible from downwind to minimize animal excitement and stress. This strategy will also minimize trap damage.

to charge just before you shoot, it may strike the barrel of the firearm, with you on the other end of it. This could cause you or someone else a serious injury. Instead, either shoot through the fence or shoot down into the trap from an elevated position (for example, while standing on an ATV or in the bed of a pickup truck). Always observe proper firearm handling and safety precautions.

SHOOTING AND HUNTING WILD PIGS

In some cases, shooting and hunting have proven effective for controlling wild pigs, but these methods require a significant amount of time and effort, and it is rare for them to be effective in substantially reducing pig numbers. Regardless of whether you are shooting at night, shooting over bait, or still hunting, not only must you be on site when the pigs are there, but it is also very difficult, if not impossible, to shoot all of the pigs you may encounter. Hunting with dogs can be effective in some situations, but this method is also ineffective in removing large numbers of pigs. Instead, shooting and hunting are best used as complements to a rigorous trapping program and not as the primary means of removal. For more information on shooting and hunting wild pigs, see *Nighttime Options for Wild Pig Control* and *Hunting Pigs with Dogs*.

Always observe proper firearm handling and safety precautions.





Chris Jaworowski
Wildlife Biologist
 Alabama Department
 of Conservation and
 Natural Resources

NIGHTTIME OPTIONS FOR WILD PIG CONTROL

Multifaceted wild pig control programs often include trapping, shooting, hunting with dogs, and even advanced techniques such as aerial gunning from helicopters. Though all of these options can reduce pig populations, they also can lead to increased nocturnal movement of wild pigs, thus reducing removal success. To maintain pressure on wild pig populations, landowners and natural resource managers often incorporate nighttime control operations to continue their “war on pigs.” Nighttime options include the use of a rifle and spotlight, night vision optics, and thermal imagery equipment.

There is a common misconception that harvesting pigs at night is easy, but this could not be further from the truth. Hunting pigs at night with rifle and spotlight is difficult, and success rates often are very low. Unlike animals such as deer, pigs lack the reflective layer in the eye that produces “eye shine.” As a result, this method often works best when conducted in open habitat types such as pastures, fields of low-growing crops, and roadsides. Spotlights with 2-3 million candlepower will easily illuminate pigs out to 100 yards in these open habitats. Also, employing this method during times of bright moonlight will increase your ability to detect and approach sounders of pigs before illuminating them for shooting.

Advances in night vision equipment have increased success rates for nighttime pig control efforts. Whereas earlier night vision optics had poor resolution and clarity, the latest models available to the public produce clearer and crisper images that make it possible to detect pigs as far out as several hundred yards. Working in total darkness, you can maneuver quietly, detect and identify pigs quickly, and then set up and take close shots. Also, because you can get much closer to pigs, night vision optics increases your chances at multiple shots from effective ranges. However, the cost of quality products is a limiting factor for most private landowners.

Thermal imaging equipment is another option available for nighttime pig control. Thermal instruments detect heat given off by all objects in nature and produce a gray-scale visual image of the heat differences. Animals appear against a gray background as if illuminated by a white light. This technology enables users to detect warm-blooded animals at distances greater than half a mile away. Because thermal imaging equipment detects the heat of all objects in nature, it does not work well in areas with a heavy forest understory or midstory. It performs best when used in open habitat types like pastures, crop fields, and roadsides.

Hunting pigs at night is not legal in all states. Be sure to check the state hunting and trapping regulations specific to the area or contact your local conservation officer.

Like night vision equipment, thermal imaging equipment is not affordable for most private landowners.

Despite ongoing control programs, wild pig populations and damage estimates continue to grow annually in the United States. Because pigs are such intelligent and highly adaptive animals, the more tools available to combat this nonnative species, the better.

NONTARGET SPECIES

When planning and implementing a wild pig control program, always consider any potential negative effects on nontarget species. Bait items such as corn, other grains, and sweet potatoes attract not only wild pigs, but also black bear, deer, and turkey. Therefore, large nontarget species may be accidentally captured in pig traps. Some state trapping laws require that any covered pig traps have an opening in the top sufficient to allow large nontarget species to escape. Depending upon opening size, black bears may escape much easier than deer. For this reason, natural resource professionals often recommend using open-topped pig traps, especially in areas with high potential for incidental capture of nontarget species. If traps with corners are used, cover only the corner portions of the trap to reduce the opportunity for pigs to climb and escape while leaving a large opening for nontarget animals to exit the trap.

Hunting and shooting wild pigs also pose potential problems for nontarget species. During low-light conditions (dawn and dusk) or in dense cover, animals such as black bear, dark-colored livestock, and dogs can be easily mistaken for wild pigs. Regardless of time of day, hunters must always make positive target identification. Always be aware of your position in relation to hunting partners, public roads, buildings, and residential areas.



Mississippi Dept. of Wildlife, Fisheries & Parks, Brad Young

Fully enclosed cage traps do not allow for the escape of nontarget species such as this Louisiana black bear, a federally protected species.



Always make positive target identification. Always be aware of your position in relation to hunting partners, public roads, buildings, and residential areas.



The American black bear is a protected species and cannot be legally harvested in many states in the Southeast. In states where black bear harvest is legal, harvests are subject to seasonal regulations. The Louisiana black bear, a subspecies of the American black bear, is federally protected and cannot be legally harvested at any time.



Scott Alls

*USDA/APHIS/Wildlife
Services*

HUNTING PIGS WITH DOGS

The tradition of hunting pigs with dogs can be traced back to early America when settlers and farmers commonly free-ranged their livestock. In order to distinguish ownership of their livestock, individuals or families would apply a unique mark—usually a series of splits or notches—to the ear or ears of individual animals. Free-ranging pigs usually were rounded up and “marked” twice per year, and the use of dogs to locate, bay, and catch these pigs made the task much easier.

Today, pig hunting with dogs has evolved into a highly popular form of sport hunting. Although this method of hunting is sometimes controversial, it serves as a valuable tool when trying to remove pigs in areas where intense shooting and trapping pressure have driven pigs to become more wary. Dogs can be used to trail these skittish pigs to their bedding areas. In addition, dog hunting pressure often will drive pigs from an area for

extended time periods. Although this is only a temporary solution, it does buy some time for planting crops and building exclusion fences.

Pig-hunting dogs are usually grouped into one of three categories: open trailing dogs, silent dogs, and catch dogs. Open trailing dogs bark while tracking or chasing pigs, whereas silent dogs do not, hence their names. Silent dogs often are more popular among hunters because they catch more pigs and races seem to be shorter, thus covering less ground and decreasing the chances of getting onto property where dogs are not welcome. Once the open trailing dogs or silent dogs have a pig at bay, the catch dog is released to move in and hold the pig—usually by the ear—until the hunters can arrive and dispatch the animal.

Though trapping is the most efficient means of removing pigs from an area, dog hunting is the most effective means of removing trap-shy or “educated” pigs that have altered their activity patterns based on previous experience with traps. However, landowners should exercise caution when employing the services of dog hunters. Be aware that some hunters catch and tie pigs and relocate them to other areas, thus creating future hunting opportunities. Therefore, be sure to ask potential hunters for references and come to an agreement that any and all pigs captured will be dispatched on site.

IS “ALL-OUT WAR” ON WILD PIGS A GOOD IDEA?

When dealing with wild pig problems, landowners often take an “all-out war” approach and, in addition to trapping, employ multiple removal techniques such as opportunistic shooting, hunting with dogs, shooting over bait, and/or shooting at night. While this approach may seem like a good way to speed up and increase the rate of wild pig removal on a property, it may actually have the opposite effect.

In most cases, trapping wild pigs using large corral-style traps is the most cost- and time-effective technique for removing them. A key component of successful pig trapping is conditioning them to the trap so the entire sounder becomes comfortable entering the trap to feed and leaving unharmed. Therefore, it stands to reason that shooting or hunting pigs with dogs while trying to trap them can result in them becoming even more wary than normal and difficult to capture. These activities also may result in pigs leaving the area for extended periods of time only to return at a later date and begin causing damage again—but now more trap-shy.

Another common mistake that leads to pigs becoming trap-shy is someone sneaking up on a trap with captured pigs inside and attempting

to shoot any pigs that may be lingering on the outside of the trap. While you may be successful in removing one or two of these pigs, most likely you will not get them all. The result: the ones you missed just received a good dose of negative reinforcement (i.e., loud noises, pigs squealing and running every which way, etc.) and will have learned that hanging around a trap is bad news. However, in situations where you know there is only one pig that consistently refuses to enter a trap based upon camera surveillance, then it would be advisable to shoot this individual at the trap if you can be assured of successful removal.

Before beginning any wild pig removal program, it is best to have a plan of when and where specific removal techniques will be used. Dealing with wild pigs can be frustrating, but give your traps time to work for you, and remember that the sooner you can capture them all and be rid of them, the sooner you can get back to doing other things. Follow up with night shooting or employ the services of someone with well-trained dogs to remove any stragglers that you could not capture in a trap. In the end, a strategic application of removal methods will likely increase your overall success and efficiency in removing wild pigs from your property.

WHERE DO WE GO FROM HERE?

Wild pigs will continue to be a management challenge for landowners and natural resource professionals for years to come. Although wild pig damage is a relatively new phenomenon in many areas of the United States, other parts of the world have been dealing with the problem of wild pigs for hundreds of years. Expanding pig populations are a global wildlife management challenge.

Many researchers agree that the most promising control techniques for the future include the use of toxicants (poisons) and contraceptives (birth control methods). Wildlife scientists have developed chemicals that will humanely kill pigs and are currently developing species-specific oral contraceptives to suppress reproduction. The problem, however, has been the development and “packaging” of a toxicant and a delivery system that will target only pigs and not other wildlife. Unfortunately, development of such a delivery system is a challenge that will likely take many years to perfect.

In the meantime, the best course of action for landowners, farmers, and natural resource professionals is to

- educate the general public, policymakers, and pig hunters about the negative impacts of wild pigs and the threats they pose to agriculture, native plant and animal

Wild pigs will continue to be a management challenge for years to come.



communities, the environment, and human health;

- promote cooperatives among adjoining landowners to reduce pig populations on larger blocks of land;
- increase state and national efforts to collect and report more accurate quantitative data on acreage and economic impacts of pig damage; and
- petition policymakers and legislative committees to strengthen current laws, restrictions, and penalties regarding translocation of wild pigs and hold owners of fenced hunting preserves liable for escaped pigs.

Until society recognizes wild pigs as a serious economic and ecological threat, and until legislation is passed that removes incentives to relocate these animals, this problem will not go away.

APPENDIX I: ZOOBOTIC DISEASES

Bacteria

Leptospirosis: The most common zoonotic disease worldwide, Leptospirosis can infect virtually all warm-blooded animals (including humans). The disease commonly affects the liver, kidney, and reproductive tract and is thus spread through urine, birthing fluids, and blood. The bacterium can survive in warm water for extended periods. Leptospirosis is usually mild, producing flu-like fever, chills, aches, pains, and jaundice. In humans, Leptospirosis usually responds to antibiotics but, if undiagnosed and untreated, can result in death.

Brucellosis: There are multiple species of this bacterium that are somewhat restricted to particular animal species, but in most species it involves the male and female reproductive system (typically causing testicular inflammation, embryonic death, or abortion and infertility). *Brucella* is capable of crossing mucous membranes and intact skin. Brucellosis infections in humans most often occur from handling infected tissues without protective hand wear. In humans, the disease produces a fever that comes and goes (undulant fever) and thus may be difficult to diagnose. Like Leptospirosis, it usually responds to long-term antibiotic therapy in humans and animals.

Salmonellosis: Many swine can harbor *Salmonella* without showing clinical signs. This bacterium is usually found in the lower gastrointestinal (GI) tract and can produce infection through fecal contamination of meat during processing or by ingestion of improperly handled or poorly stored meat products. In humans, Salmonellosis begins with diarrhea and vomiting and if untreated may progress to blood poisoning, dehydration, and death. Like other bacteria, this disease can respond to proper antibiotic therapy.

Viruses

Rabies: This disease is usually transmitted only through the bite of a rabid animal and affects primarily the nervous system. Rabid animals usually exhibit abnormal behavior, and the disease is ultimately fatal in most hosts. Rabies is a reportable disease and can only be confirmed by an approved public health laboratory.

Influenza viruses: Swine can serve as a reservoir and amplifying host for influenza viruses. Signs of influenza in humans and animals can range from extremely mild, with some systemic or respiratory signs (such as cough, aches, and chills) to an overwhelming multisystemic and occasionally fatal disease. However, prevalence of these diseases is thought to be low, and direct transmission to humans has not been demonstrated.

Parasites

Trichinella: This round worm localizes within the muscles of humans and swine and also cycles through wild rodents. When ingested in undercooked meat, *Trichinella* can localize in muscle tissue and produce intense pain in humans.

Giardia* and *Cryptosporidium: These protozoan parasites affect many animals. They localize in the lower GI tract and produce cramps and diarrhea that may lead to dehydration and death if untreated. These agents are shed in the feces of the primary host and gain entrance to the secondary host through water contaminated with fecal matter or improperly handled food products. Each of these parasites is treatable upon proper diagnosis.

APPENDIX II: THE CORRAL TRAP

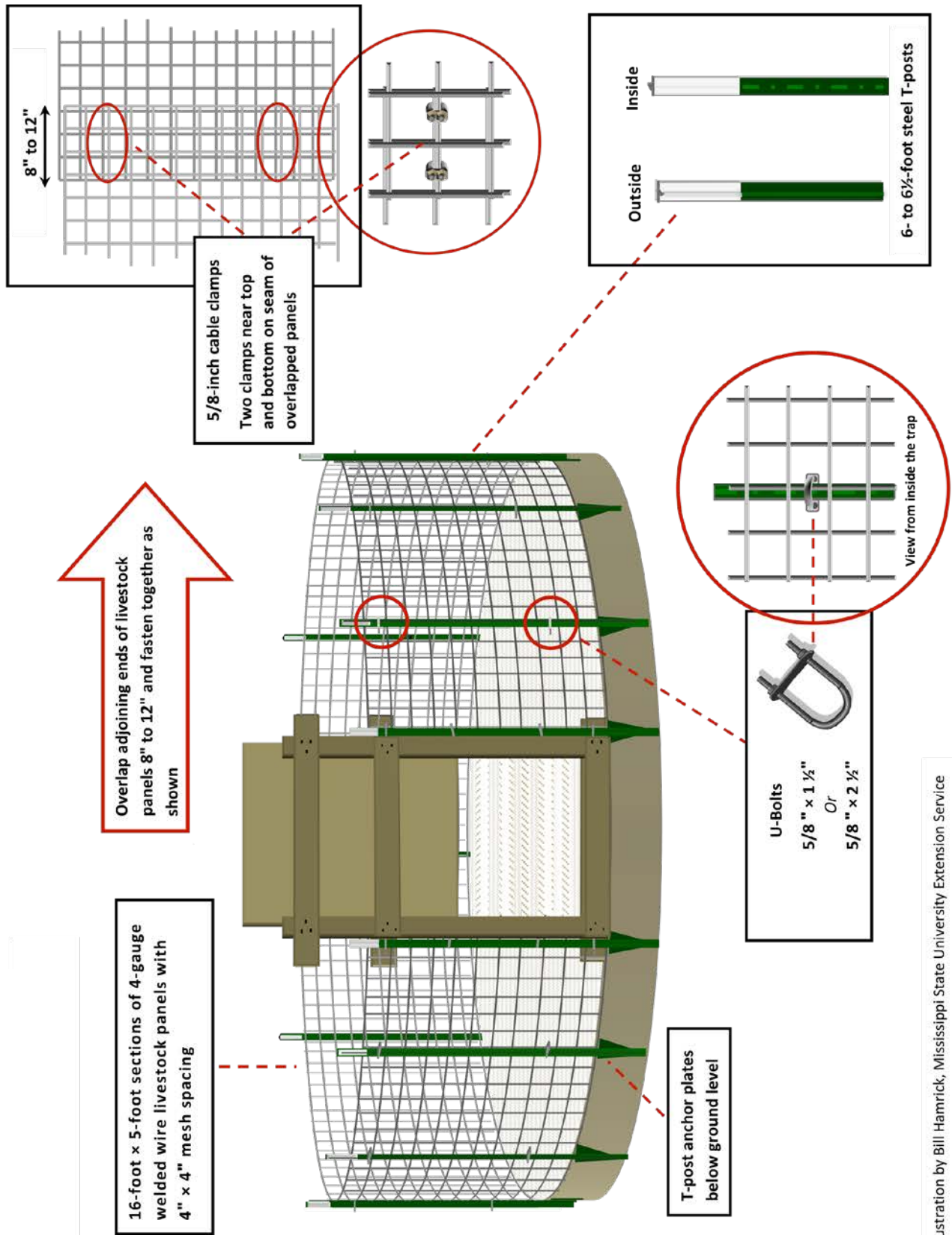

APPENDIX III: TRAP DOOR DESIGNS

POOR MAN'S TRAP DOOR

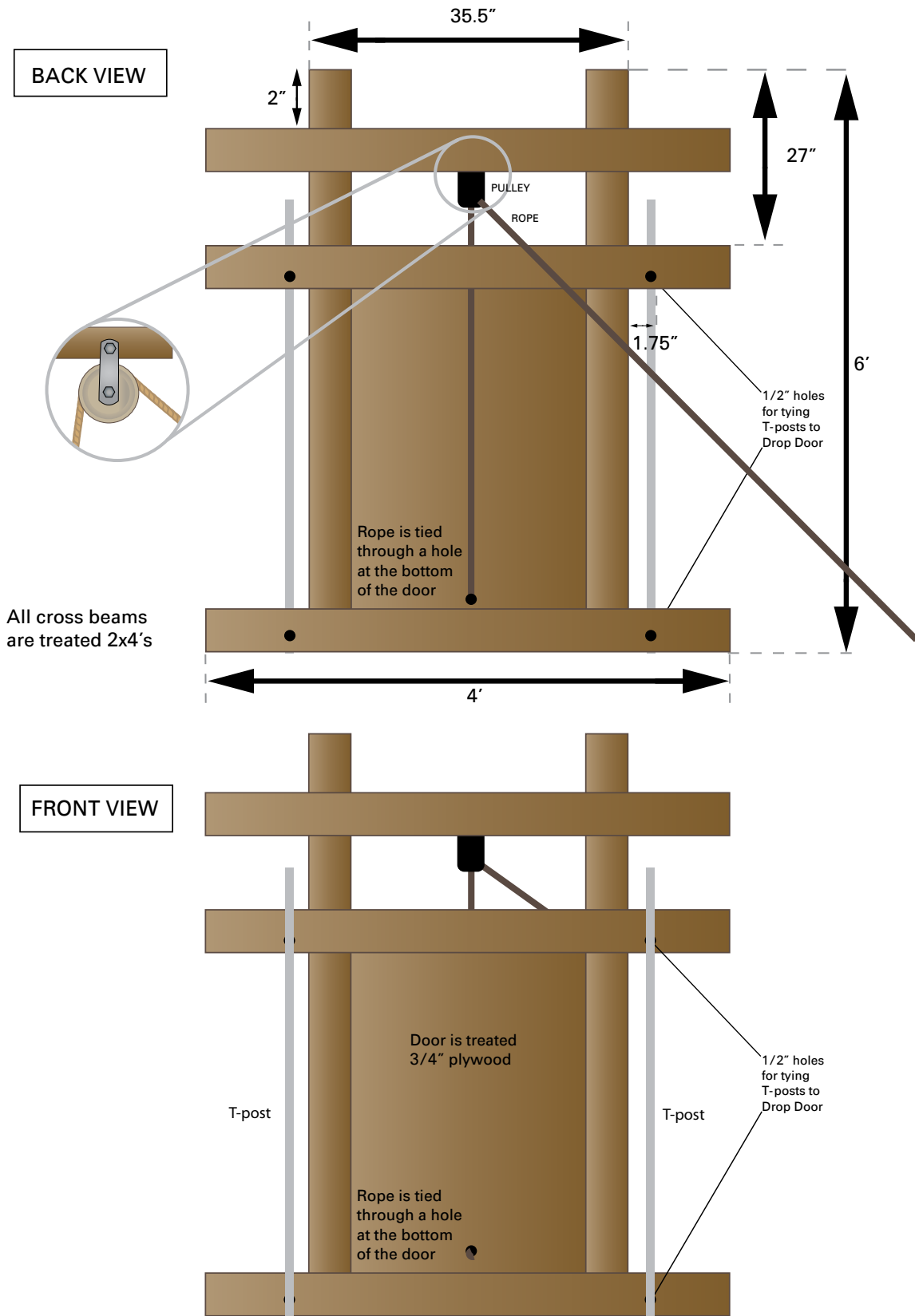

POOR MAN'S TRAP DOOR

BIRD'S EYE VIEW

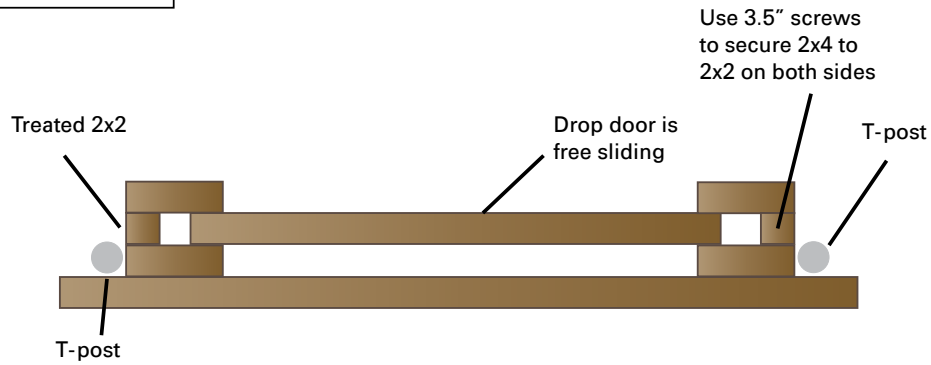

DROP DOOR ONLY

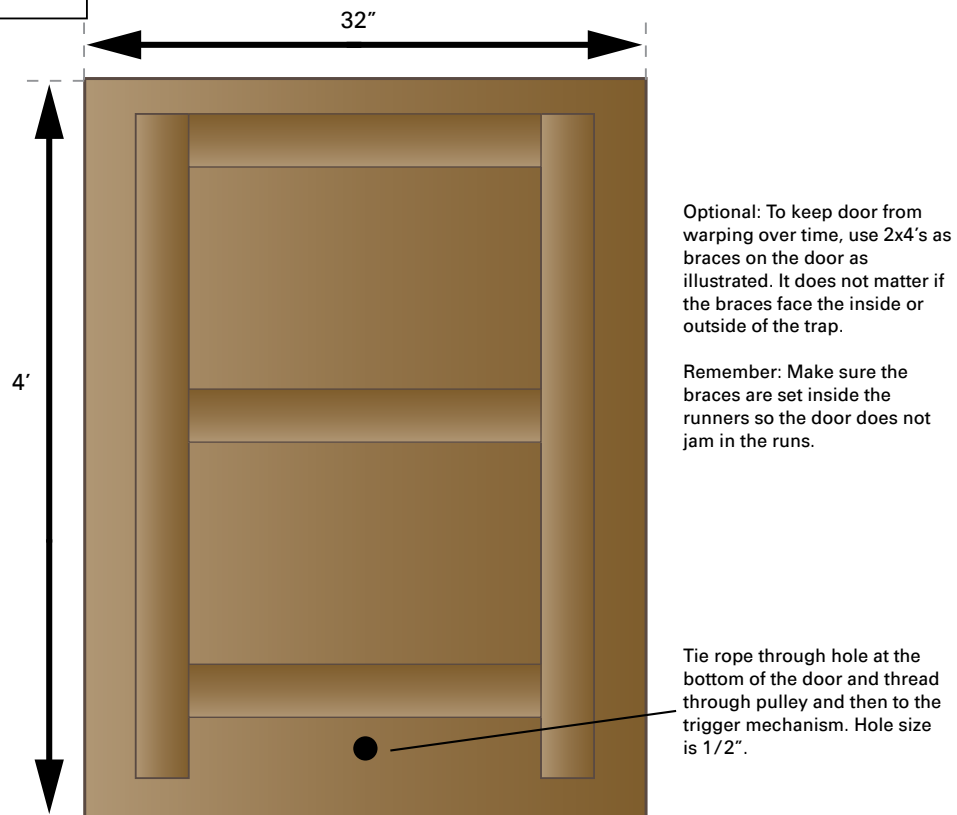

Trap Design by Parker Hall Wildlife Biologist

Original Graphics Design by Dana Johnson – Wildlife Biologist – auburnwildlife@bellsouth.net.

Trap design may not be reprinted or published in any periodical or web site without the expressed written consent of the above designers, Dr. Jim Armstrong or Andy Whittaker.

Design may be e-mailed to others wishing to build this trap. Check local state game laws before building. Any questions about the trap may be sent to the above e-mail address.

KERRVILLE HOG ROOTER GATE

Kerrville Rooter Gate w/ Trigger
Sht. 1

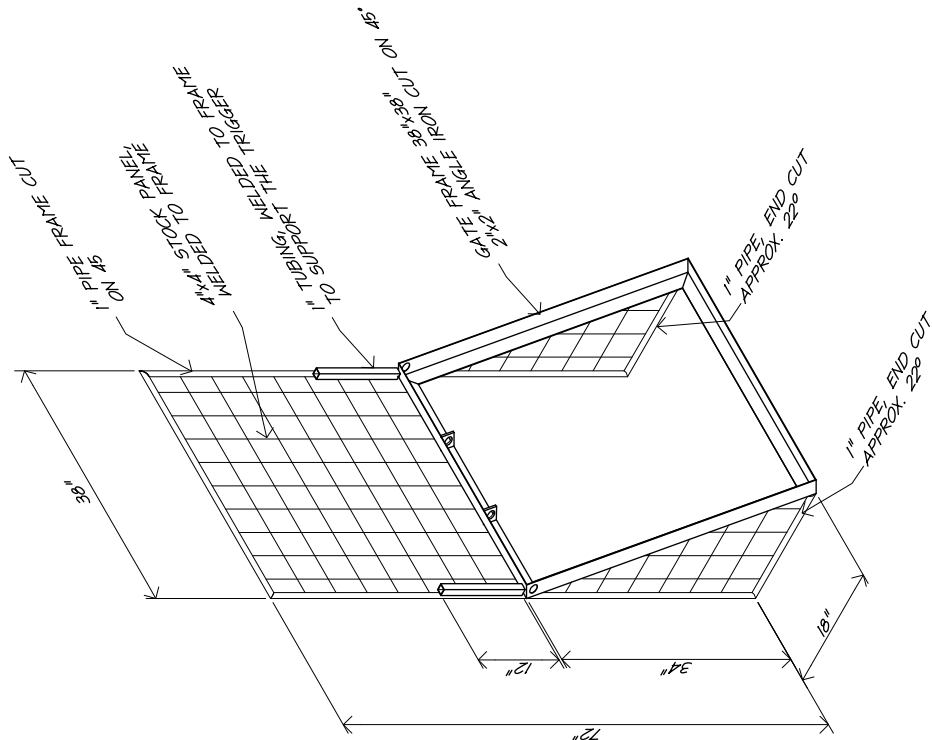
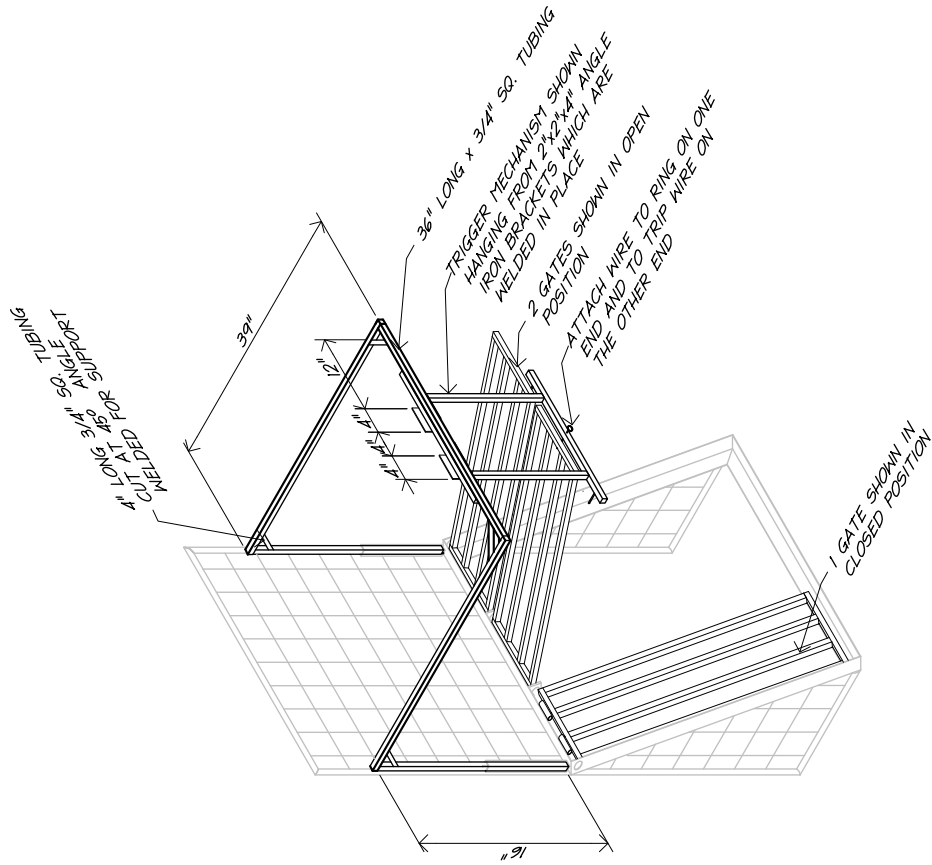

KERRVILLE HOG ROOTER GATE

SCALE: 1/2" = 1'-0"

KERRVILLE HOG ROOTER GATE PANEL

SCALE: 1/2" = 1'-0"

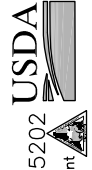

United States Dept. of Agriculture • Wildlife Services • (573)449-3033 • 1714 Commerce Court, Suite C, Columbia, MO 65202
 Designed by Bob Sims (TX USDA) • Drafted by Rhonda Bonnot (MDC) • Trigger Design by Dan McMurtry (MO. USDA) With cooperation from MDC Design & Development

KERRVILLE HOG ROOTER GATE

Kerrville Hog Rooter Gate w/ Trigger
Sht 2

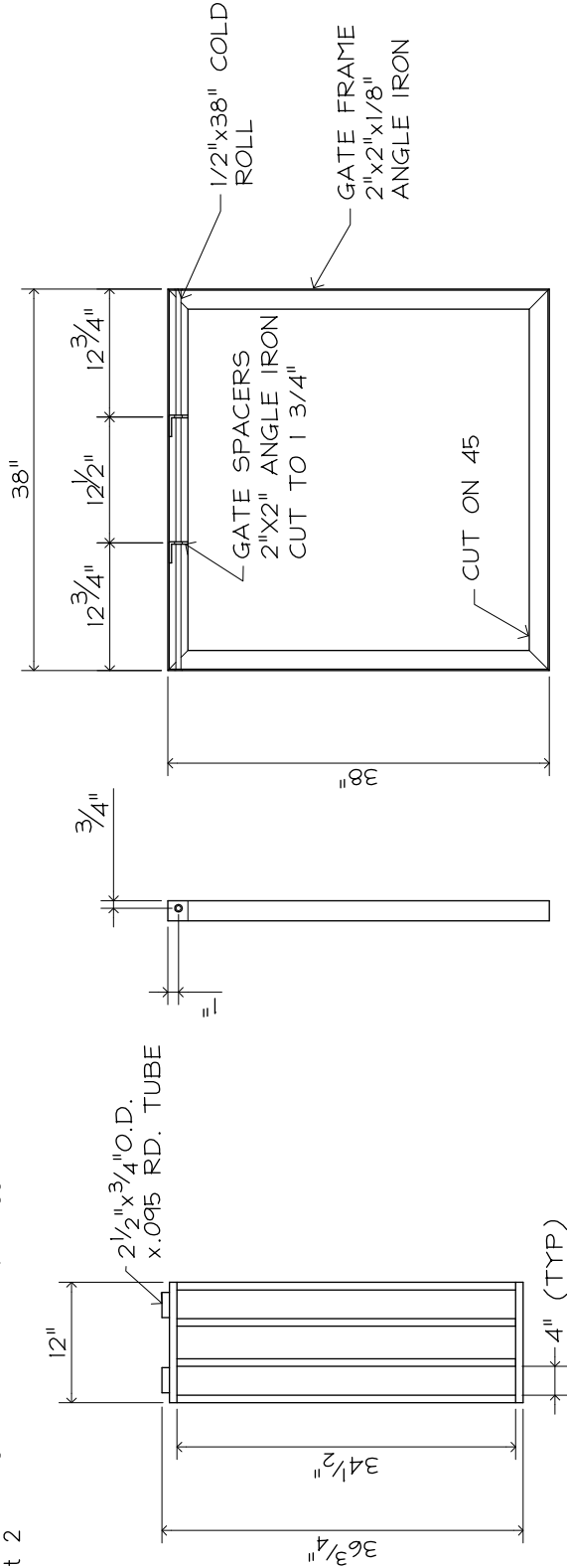

GATE DETAIL (TYPICAL OF 3)

SCALE: 3/4" = 1'-0"

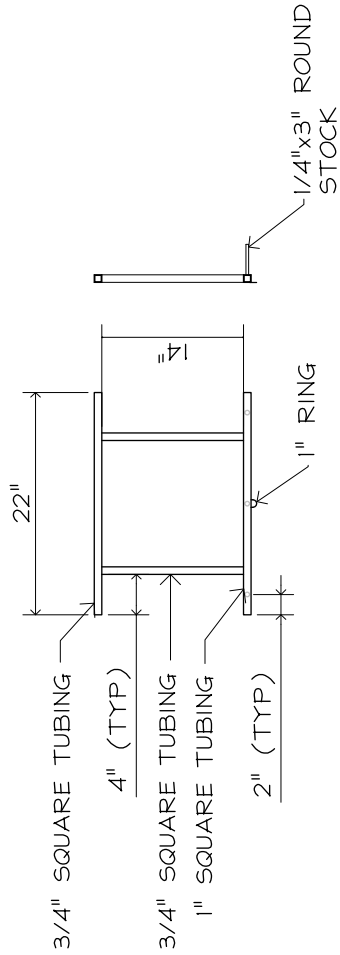

TRIGGER MECHANISM

SCALE: 3/4" = 1'-0"

GATE FRAME DETAIL

SCALE: 3/4" = 1'-0"

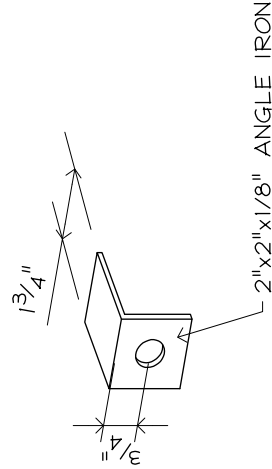

SPACER

SCALE: 3" = 1'-0"



DOUBLE SPRING OR SALOON-STYLE TRAP DOOR

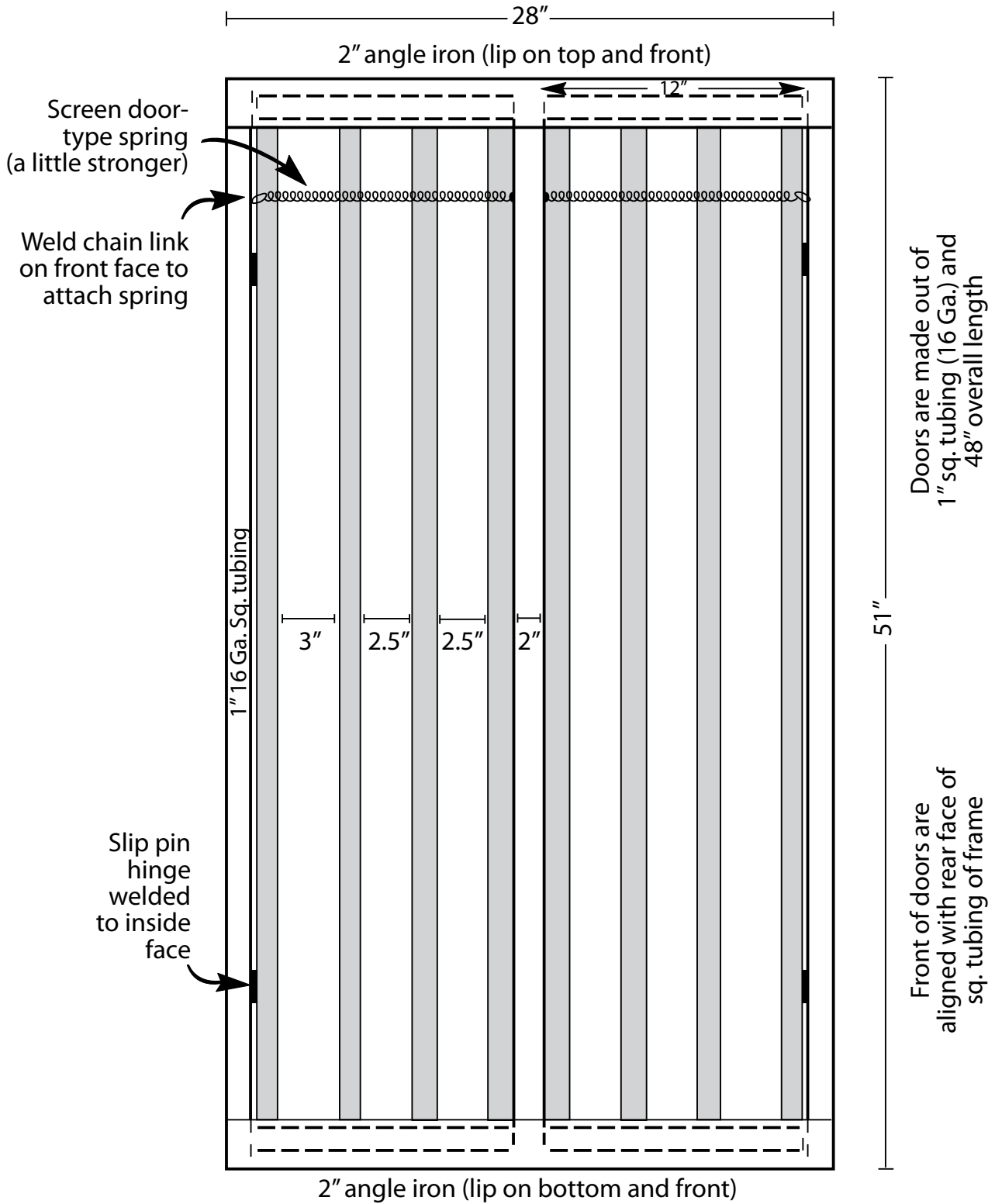

APPENDIX IV: TRIGGER MECHANISMS

THE ROOT STICK

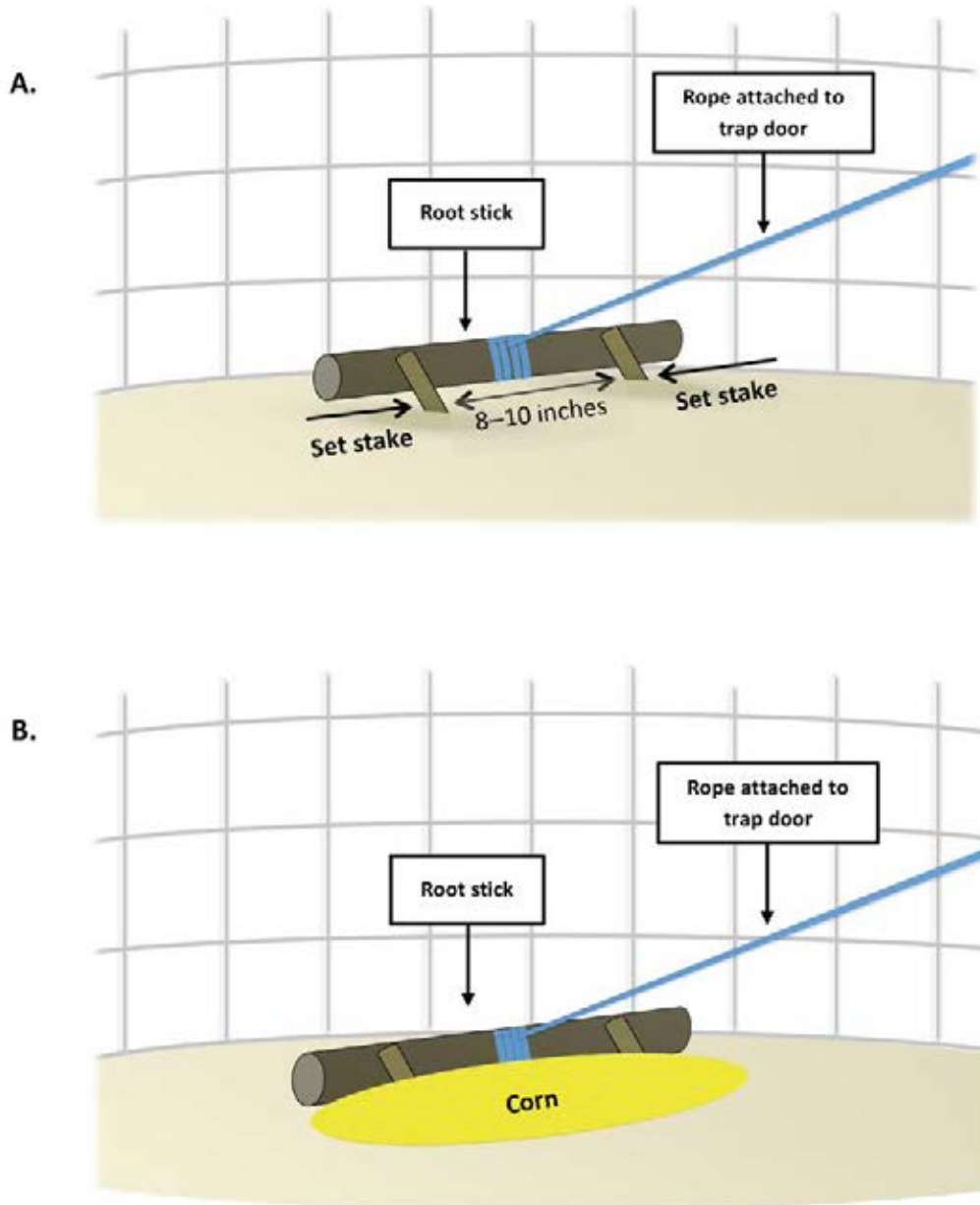
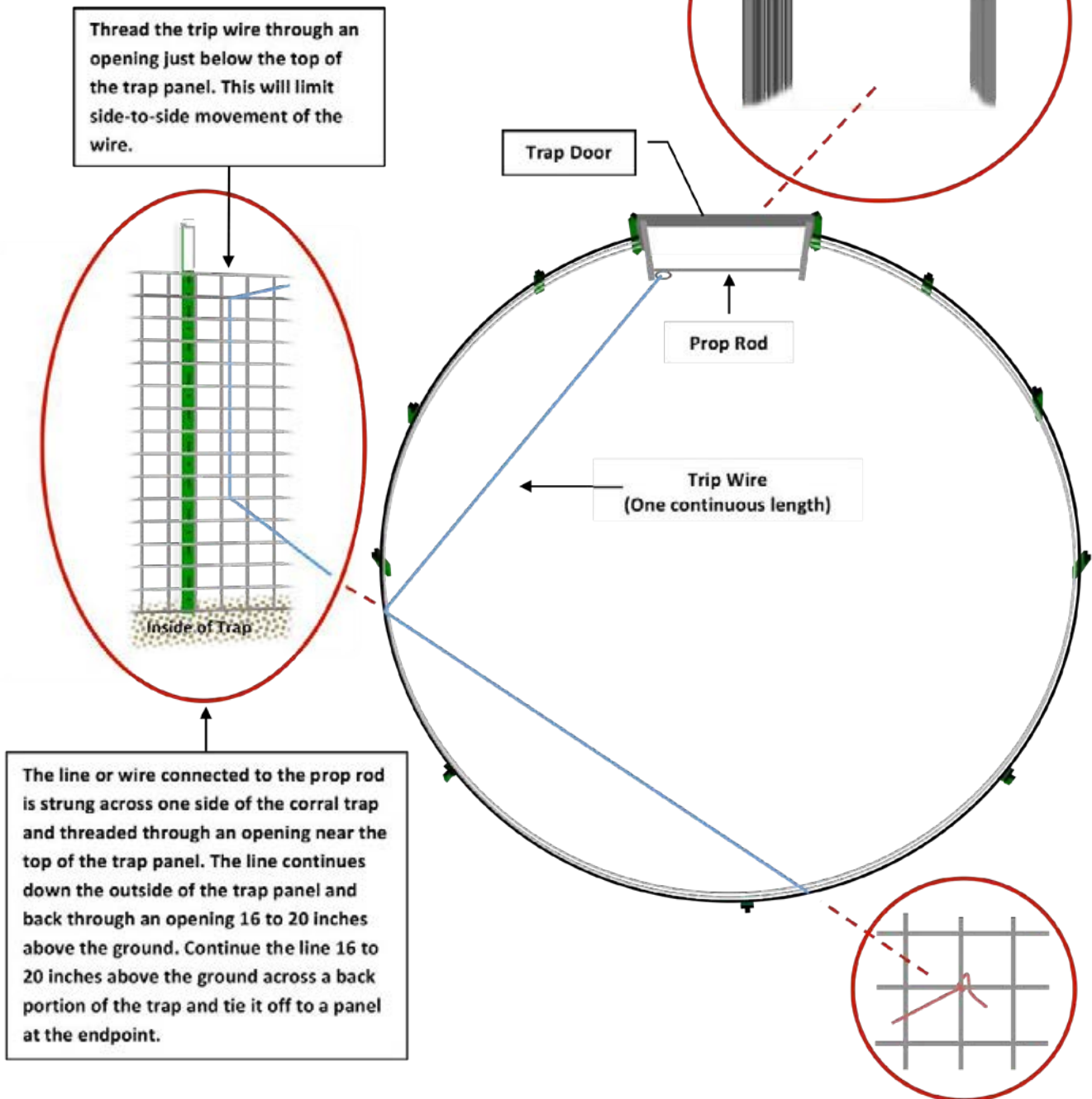

Illustration by Bill Hamrick, Mississippi State University Extension Service

(A) Placement of set stakes (45° to 60° angle) and root stick when the trap is set. (B) Bait placement around the root stick when the trap is set. As pigs feed and root around the trigger mechanism, the root stick is dislodged from behind the set stakes and the trap is sprung. Trigger sensitivity can be adjusted by positioning the root stick higher or lower behind the set stakes.

THE TRIP WIRE

Note: Trip wires can be used with both single-catch trap doors and multi-catch trap doors.



CONVERTING A ROOT STICK TRIGGER TO A TRIP WIRE

(Use only with sliding drop doors)

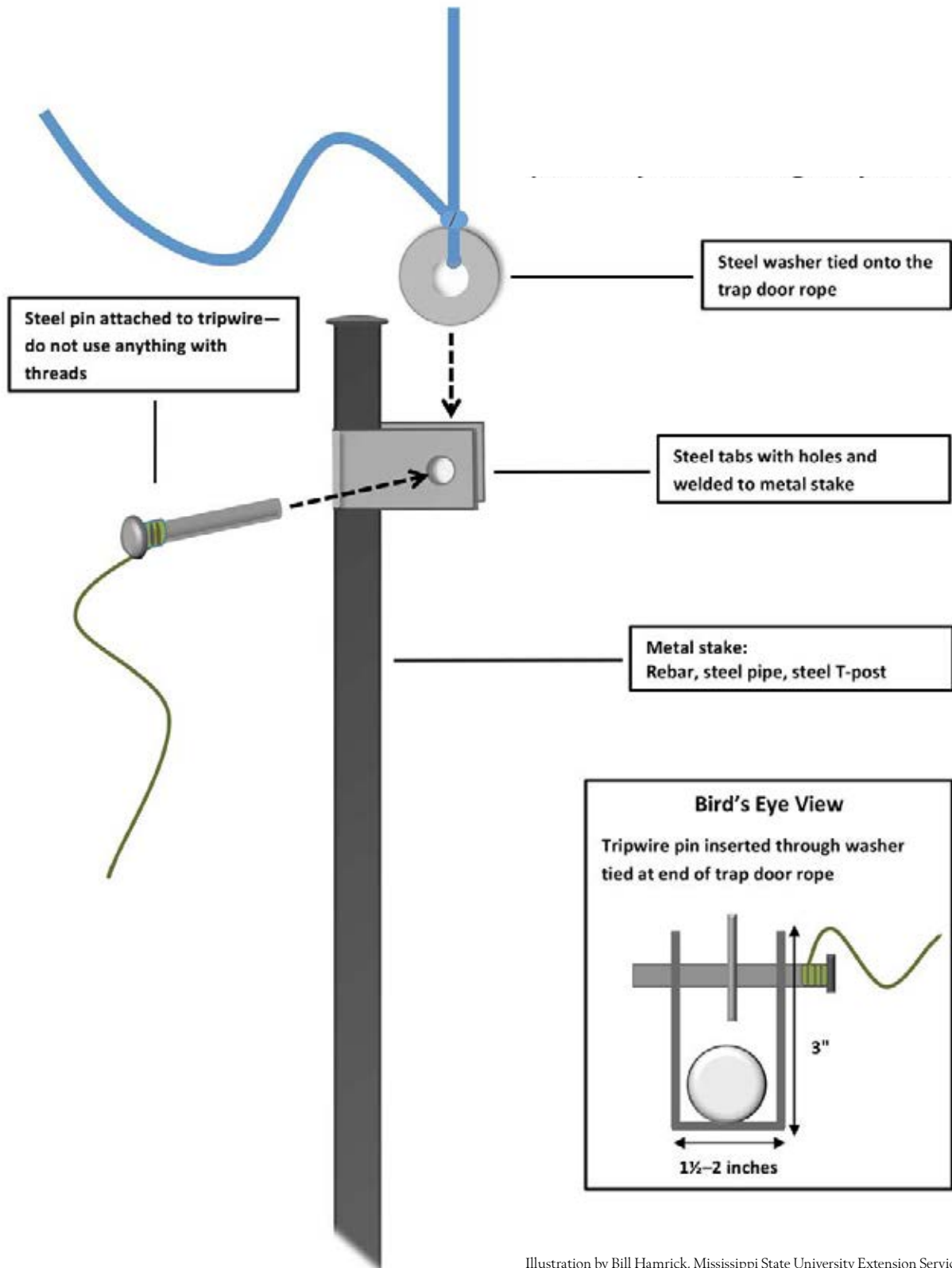

CONVERTING A ROOT STICK TRIGGER TO A TRIP WIRE

(Use only with sliding drop doors)

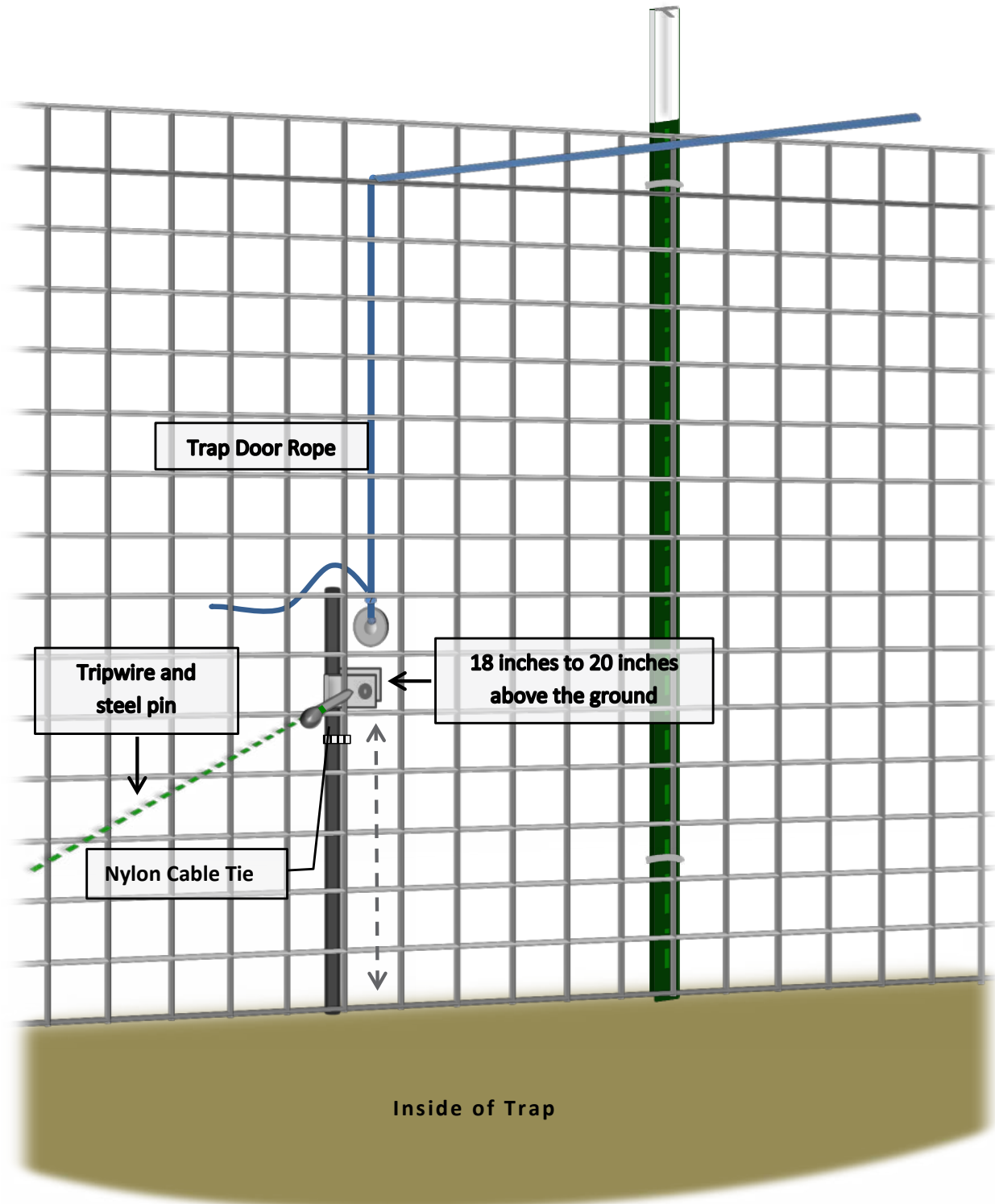

CONVERTING A ROOT STICK TRIGGER TO A TRIP WIRE

(Use only with sliding drop doors)

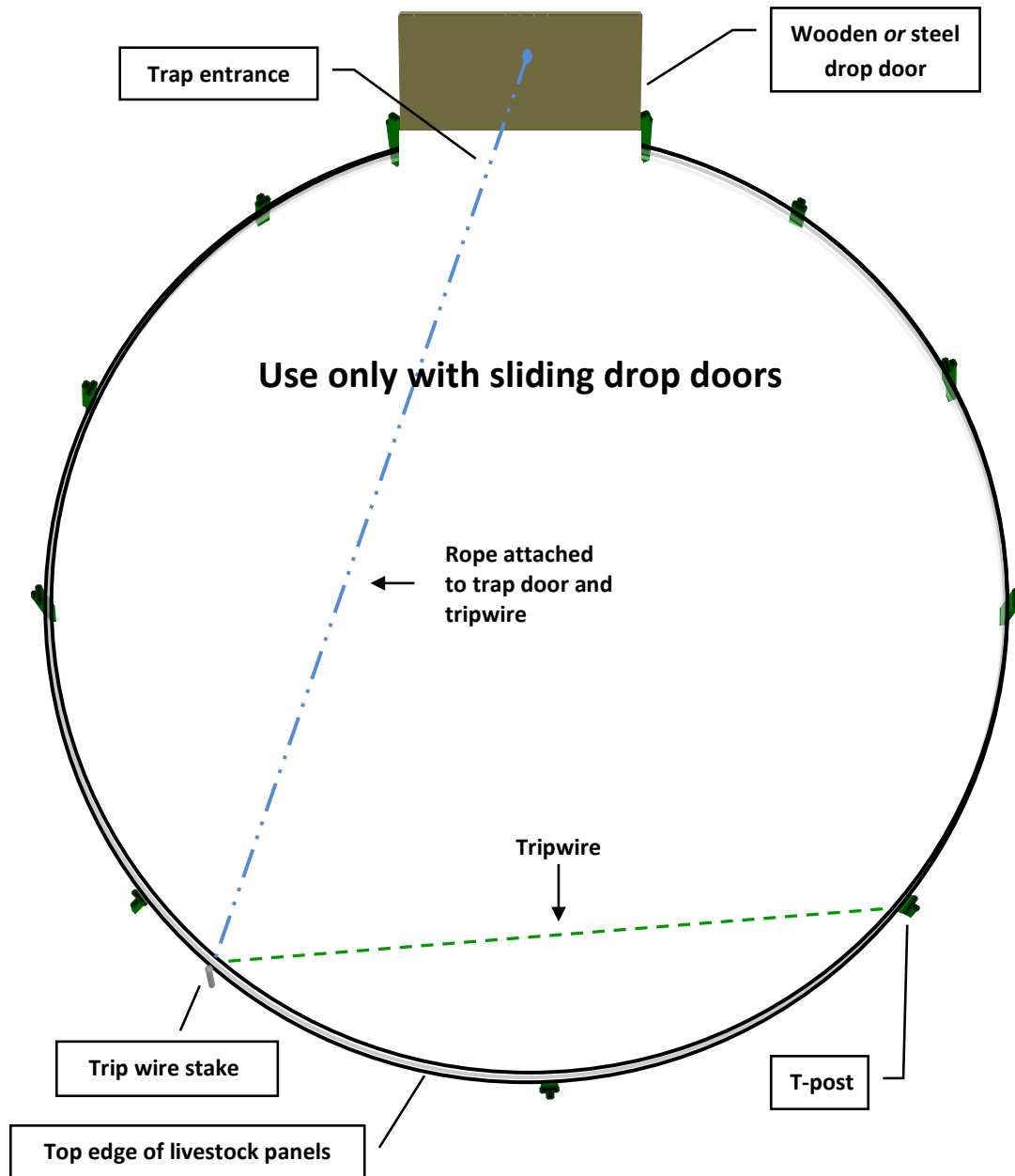

Illustration by Bill Hamrick, Mississippi State University Extension Service

Overhead view of a corral trap in which the root stick trigger has been converted to a trip wire.

APPENDIX V: MONITORING PIG TRAPS AND STRATEGIC BAITING

POSITIONING GAME CAMERAS TO MONITOR PIG TRAPS

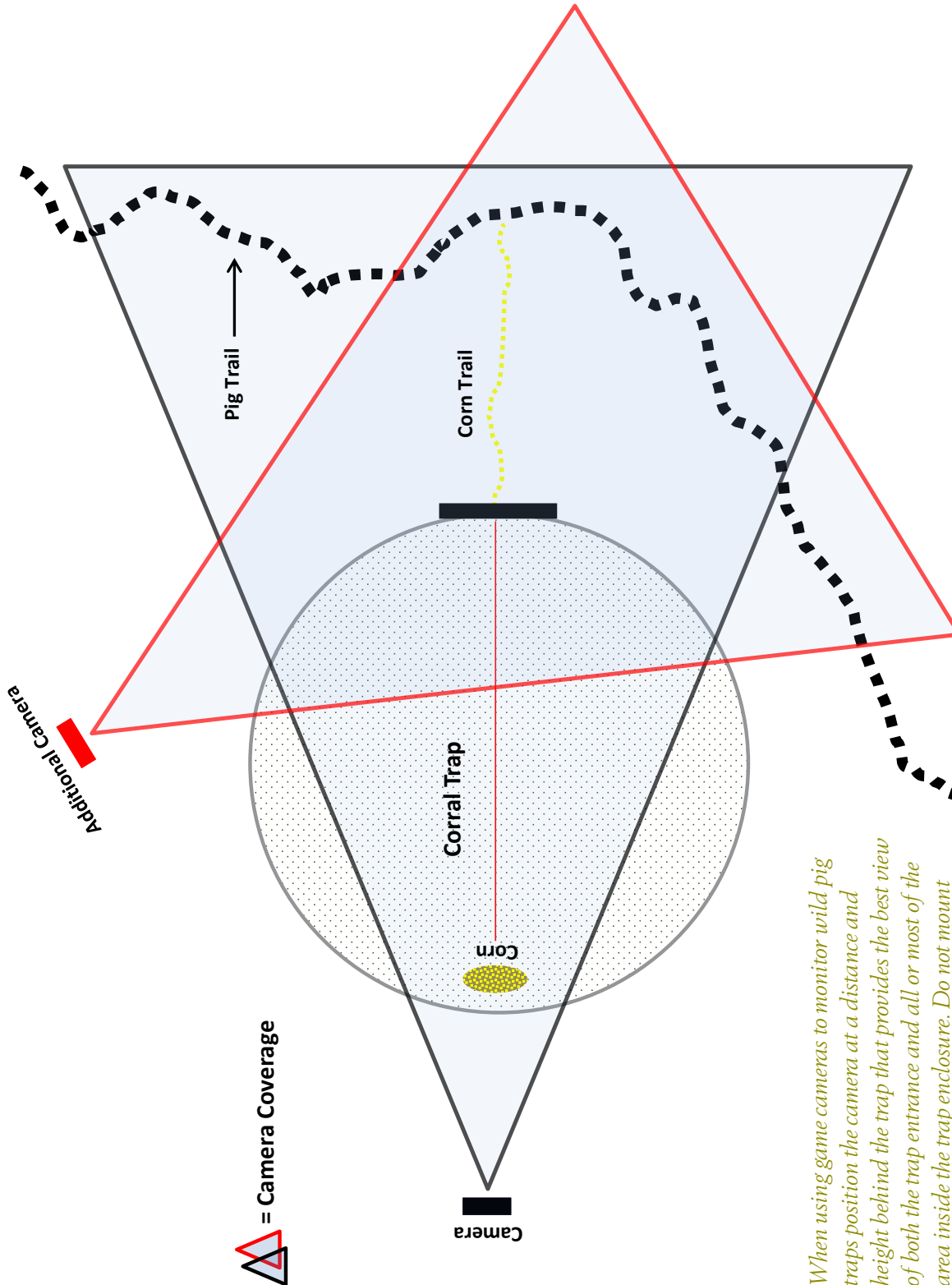

Illustration by Jay Cumber, USDA/APHIS—Wildlife Services

When using game cameras to monitor wild pig traps position the camera at a distance and height behind the trap that provides the best view of both the trap entrance and all or most of the area inside the trap enclosure. Do not mount game cameras on the trap panels. An additional camera positioned to monitor the trap entrance from a different angle can be useful in providing information about pig behavior outside the trap and whether or not other pigs are lingering out of view of the camera at the rear of the trap.

BAITING A WILD PIG TRAP

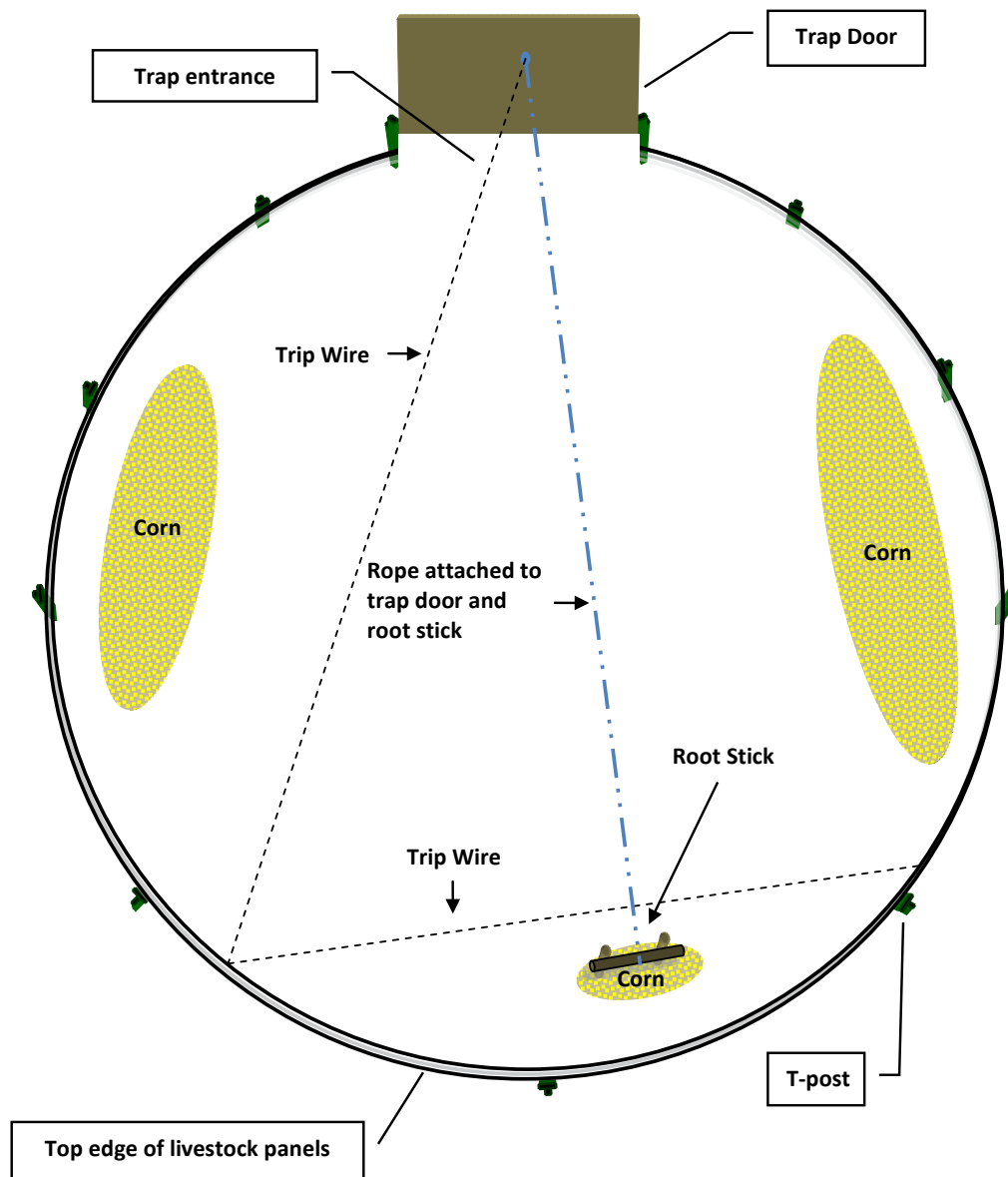

Illustration by Bill Hamrick, Mississippi State University Extension Service

This illustration shows an overhead view of a corral trap demonstrating bait placement for trapping wild pigs. Place only ½ to 1 gallon of corn around the root stick or behind the tripwire (a 5-gallon bucket of corn is sufficient for baiting a four-panel trap). The rationale behind this strategy is that, upon entering the trap, pigs will begin feeding on the large bait piles. As more pigs enter the trap, juvenile and subordinate pigs are pushed off the large bait piles. These pigs then migrate to the smaller bait pile at the back of the trap and eventually walk into the trip wire or dislodge the root stick and spring the trap. The same strategy applies whether using a root stick trigger or a trip wire.

BAITING A WILD PIG TRAP USING A SPIN-CAST FEEDER

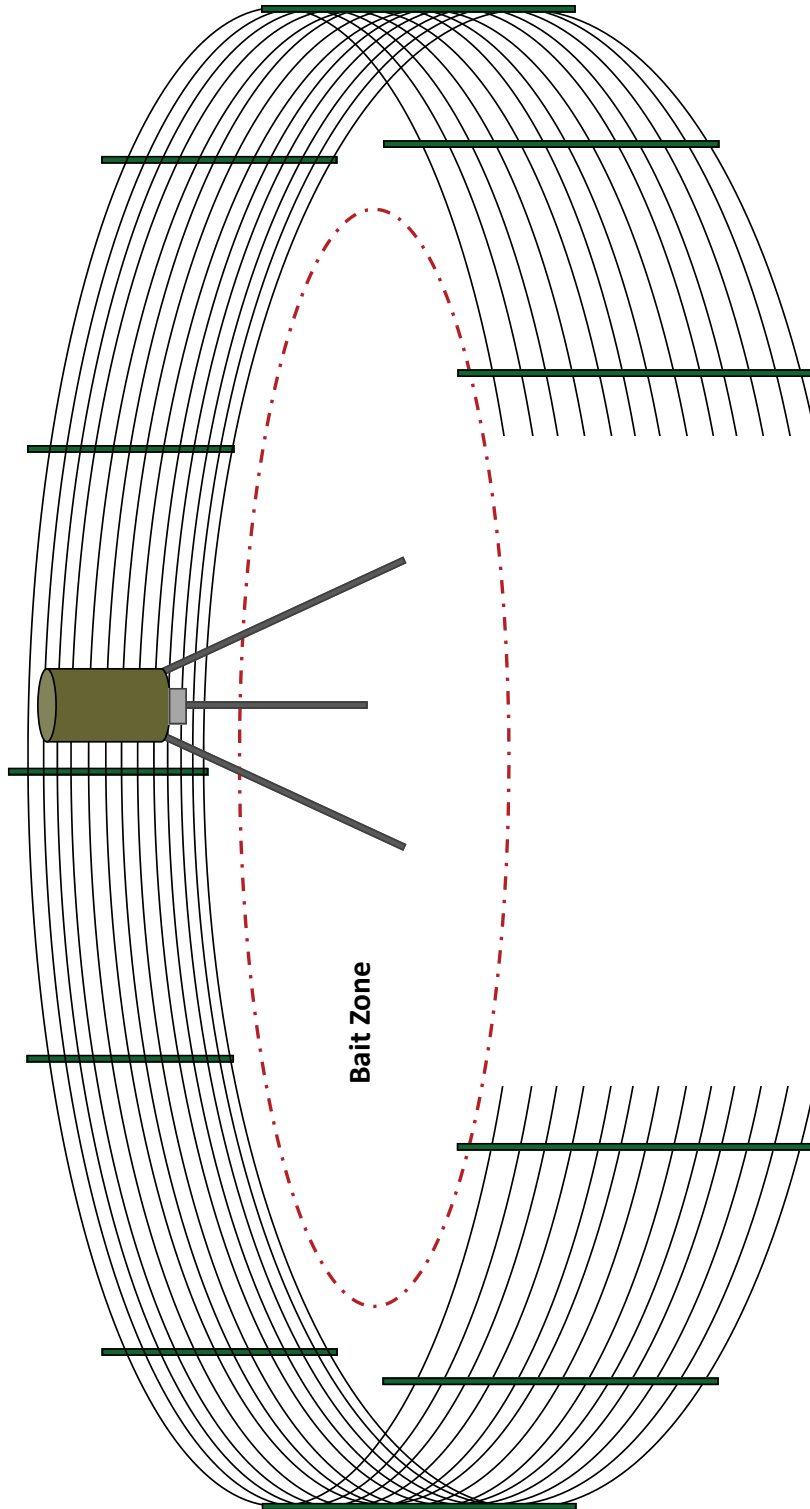

Illustration by Bill Hamrick, Mississippi State University Extension Service

When using a corral trap equipped with a remote gate and an automatic spin-cast feeder, make sure that corn is not being dispensed outside the trap enclosure. Attach a paper feed sack or some other material or object of similar stiffness to the entrance side of the feeder to limit the distance corn is dispensed in the direction of the entrance.

GLOSSARY

- **Boar:** A male pig of any age with intact testicles.
- **Eurasian wild boar:** Free-ranging, wild pigs (male and female) of the “western race” subspecies native to Europe, Russia, and the Middle East, extending as far as Central Asia, including central and southern Russia, Kazakhstan, northern Afghanistan, etc.
- **Farrow:** To give birth to pigs.
- **Reportable disease:** A disease that must be reported to federal, state, or local animal or human health officials when diagnosed.
- **Shoat:** A young pig that has been weaned.
- **Sounder:** A social unit of pigs usually consisting of two to three related adult sows, their piglets, and both juvenile males and females from previous litters.
- **Sow:** A female pig that has farrowed at least once.
- **Zoonotic:** A disease transmissible from animals to humans.

NOTES

ADDITIONAL RESOURCES



www.wildpiginfo.com



www.extension.org/feral_hogs



www.humanwildlifeconflicts.msstate.edu



AUTHORS

BILL HAMRICK

Extension Associate III, Department of Wildlife, Fisheries, and Aquaculture, Mississippi State University

MARK D. SMITH

Associate Professor/Extension Specialist, Alabama Cooperative Extension System, School of Forestry and Wildlife Sciences, Auburn University

CHRIS JAWOROWSKI

Wildlife Biologist, Alabama Department of Conservation and Natural Resources, Division of Wildlife and Freshwater Fisheries—Wildlife Section

BRONSON STRICKLAND

Associate Professor/Extension Specialist, Department of Wildlife, Fisheries, and Aquaculture, Mississippi State University



EXTENSION



Protecting People | Protecting Agriculture | Protecting Wildlife

Support for this project was provided by



United States Department of Agriculture
National Institute of Food and Agriculture

Copyright 2016 by Mississippi State University. All rights reserved. This publication may be copied and distributed without alteration for nonprofit educational purposes provided that credit is given to the Mississippi State University Extension Service.

Produced by Agricultural Communications

We are an equal opportunity employer, and all qualified applicants will receive consideration for employment without regard to race, color, religion, sex, national origin, disability status, protected veteran status, or any other characteristic protected by law.

Publication 2659

Extension Service of Mississippi State University, cooperating with U.S. Department of Agriculture. Published in furtherance of Acts of Congress, May 8 and June 30, 1914. GARY B. JACKSON, Director (22M-2-16)

Publication ANRE-1397, Alabama Cooperative Extension System

